

Technische Information / Technical Information

eupec

Lichtgezündeter Netz Thyristor
mit integriertem. Überspannungsschutz

T 2563 N 75 TOH

Phase Control Thyristor, light triggered
with integrated overvoltage protection

Vorläufige Daten / Provisional Data

N

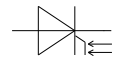

Elektrische Eigenschaften / Electrical properties

Höchstzulässige Werte / Maximum rated values

Periodische Rückwärts-Spitzensperrspannung repetitive peak reverse voltage	$t_{vj} = -40^{\circ}\text{C} \dots t_{vj\text{ max}}$	V_{RRM}	7500	V
Durchlaßstrom-Grenzeffektivwert RMS forward current		I_{TRMSM}	5600	A
Dauergrenzstrom mean forward current	$t_c = 85^{\circ}\text{C}, f = 50\text{Hz}$ $t_c = 60^{\circ}\text{C}, f = 50\text{Hz}$	I_{TAVM}	2560 3570	A A
Stoßstrom-Grenzwert surge forward current	$t_{vj} = 25^{\circ}\text{C}, t_p = 10\text{ms}$ $t_{vj} = t_{vj\text{ max}}, t_p = 10\text{ms}$	I_{TSM}	63 56	kA kA
Grenzlastintegral I^2t -value	$t_{vj} = 25^{\circ}\text{C}, t_p = 10\text{ms}$ $t_{vj} = t_{vj\text{ max}}, t_p = 10\text{ms}$	I^2t	$19,8 \cdot 10^6$ $15,7 \cdot 10^6$	A^2s A^2s
Kritische Stromsteilheit, periodisch critical rate of rise of on-state current, periodical	DIN IEC 747-6 $V_D \leq V_{BO}, f = 50\text{Hz}, P_L = 40\text{mW},$ $t_{rise} = 0,5\mu\text{s}$	$(di/dt)_{cr}$	300	$\text{A}/\mu\text{s}$
Kritische Stromsteilheit, nicht-periodisch critical rate of rise of on-state current, non-periodical	DIN IEC 747-6 $V_D \leq V_{BO}, P_L = 40\text{mW}, t_{rise} = 0,5\mu\text{s}$	$(di/dt)_{cr}$	1000	$\text{A}/\mu\text{s}$
Kritische Spannungssteilheit critical rate of rise of off-state current	$t_{vj} = t_{vj\text{ max}}, v_{DM} = 5\text{kV}$	$(dv/dt)_{cr}$	2000	$\text{V}/\mu\text{s}$

Charakteristische Werte / Characteristic values

Schutzzündspannung (statisch) protective break over voltage	$t_{vj} = 0^{\circ}\text{C} \dots t_{vj\text{ max}}$	V_{BO}	min. 7500	V
Durchlaßspannung on-state voltage	$t_{vj} = t_{vj\text{ max}}, i_T = 6\text{kA}$	V_T	typ. 2,75 max. 2,95	V
Schleusenspannung / threshold voltage Ersatzwiderstand / slope resistance	$t_{vj} = t_{vj\text{ max}}$	V_{TO} r_T	typ. 1,23 0,253 max. 1,28 0,278	V m Ω
Durchlaßrechenkennlinie on-state characteristics for calculations $V_T = A + B \cdot i_T + C \cdot \ln(i_T + 1) + D \cdot \sqrt{i_T}$	$t_{vj} = t_{vj\text{ max}}$	A B C D	typ. -0,00607 0,000181 0,162 0,00342 max. -0,00503 0,000187 0,160 0,00570	
erforderliche Zündlichtleistung required gate trigger light power	$t_{vj} = 25^{\circ}\text{C}, v_D = 50\text{V}$	P_{LM}	max. 40	mW

Technische Information / Technical Information

eupec

Lichtgezündeter Netz Thyristor
mit integriertem Überspannungsschutz

T 2563 N 75 TOH

Phase Control Thyristor, light triggered
with integrated overvoltage protection

Vorläufige Daten / Provisional Data

N

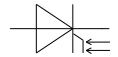

Elektrische Eigenschaften / Electrical properties

Charakteristische Werte / Characteristic values

Haltestrom holding current	$t_{ij} = 25^{\circ}\text{C}$	I_H	max.	100	mA
Einraststrom latching current	$t_{ij} = 25^{\circ}\text{C}, V_D = 50\text{V},$ $P_{LM} = 40\text{mW}, t_{an} = 0,5\mu\text{s}$	I_L	max.	100	mA
Vorwärts- und Rückwärts-Sperrstrom forward off-state and reverse currents	$t_{ij} = t_{ij\text{ max}}$ $V_D = V_R = 7500\text{V}$	i_D, i_R	max.	900	mA
Zündverzögerung gate controlled delay time	$V_D = 1000\text{V}, t_{ij} = 25^{\circ}\text{C},$ $P_{LM} = 40\text{mW}, t_{an} = 0,5\mu\text{s}$	t_{gd}	typ.	5	μs
Freiwerdezeit circuit commutated turn-off time	$t_{ij} = t_{ij\text{ max}}, i_{TM} = I_{TAVM}$ $V_{RM} = 100\text{V}, v_{DM} = 0,67 \cdot v_{DRM}$ $dv_D/dt = 20\text{V}/\mu\text{s}, -di_T/dt = 10\text{A}/\mu\text{s}$ 4. Kennbuchstabe / 4 th letter O	t_q	typ.	550	μs
Sperrverzögerungsladung recovered charge	$t_{ij} = t_{ij\text{ max}}$ $I_{TM} = 4000\text{A}, di/dt = 10\text{A}/\mu\text{s}$ $V_R = 0,5 \cdot V_{RRM}, V_{RM} = 0,8 \cdot V_{RRM}$	Q_r	max.	19	mAs
Rückstromspitze peak reverse recovery current	$t_{ij} = t_{ij\text{ max}}$ $I_{TM} = 4000\text{A}, di/dt = 10\text{A}/\mu\text{s}$ $V_R = 0,5 \cdot V_{RRM}, V_{RM} = 0,8 \cdot V_{RRM}$	I_{RM}	max.	400	A

Technische Information / Technical Information

eupec

Lichtgezündeter Netz Thyristor
mit integriertem Überspannungsschutz

T 2563 N 75 TOH

Phase Control Thyristor, light triggered
with integrated overvoltage protection

Vorläufige Daten / Provisional Data

N

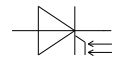

Thermische Eigenschaften / Thermal properties

Innerer Wärmewiderstand thermal resistance, junction to case	Kühlfläche / cooling surface beidseitig / two-sided, $\theta = 180^\circ \sin$ beidseitig / two sided, DC	R_{thJC}	0,0046 0,0043	$^\circ\text{C/W}$ $^\circ\text{C/W}$
Übergangs-Wärmewiderstand thermal resistance, case to heatsink	Kühlfläche / cooling surface beidseitig / two-sided	R_{thCK}	0,0010	$^\circ\text{C/W}$
Höchstzulässige Sperrschichttemperatur max. junction temperature		$t_{vj \max}$	+120	$^\circ\text{C}$
Betriebstemperatur operating temperature		$t_{c \text{ op}}$	0...+120	$^\circ\text{C}$
Lagertemperatur storage temperature		t_{stg}	-40...+150	$^\circ\text{C}$

Mechanische Eigenschaften / Mechanical properties

Gehäuse, siehe Anlage case, see appendix			Seite 4	
Si-Element mit Druckkontakt, Lichtzündung Si-pellet with pressure contact, light triggered	Silizium Tablette silicon wafer		119TN80	
Anpreßkraft clamp force		F	90...130	kN
Gewicht weight		G	typ. 4000	g
Kriechstrecke creepage distance			33	mm
Feuchteklasse humidity classification	DIN 40040		C	
Schwingfestigkeit vibration resistance	f = 50Hz		50	m/s^2

Mit dieser technischen Information werden Halbleiterbauelemente spezifiziert, jedoch keine Eigenschaften zugesichert. Sie gilt in Verbindung mit den zugehörigen technischen Erläuterungen.
This technical information specifies semiconductor devices but promises no characteristics. It is valid in combination with the belonging technical notes.

Lichtgezündeter Netz Thyristor
mit integriertem. Überspannungsschutz

T 2563 N 75 TOH

Phase Control Thyristor, light triggered
with integrated overvoltage protection

Vorläufige Daten / Provisional Data

N

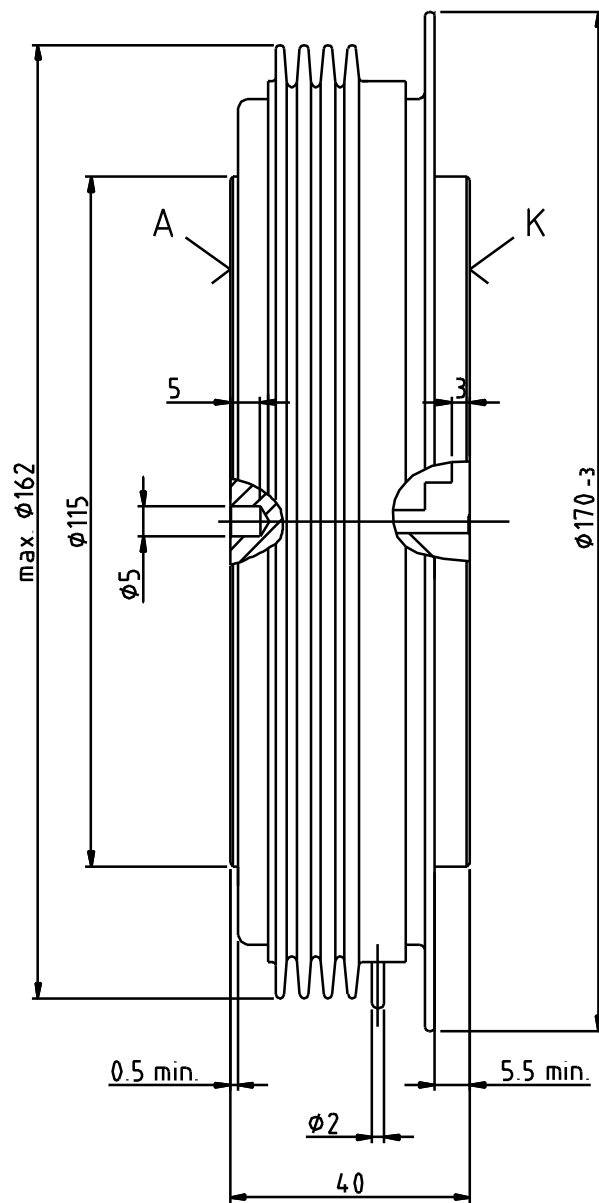
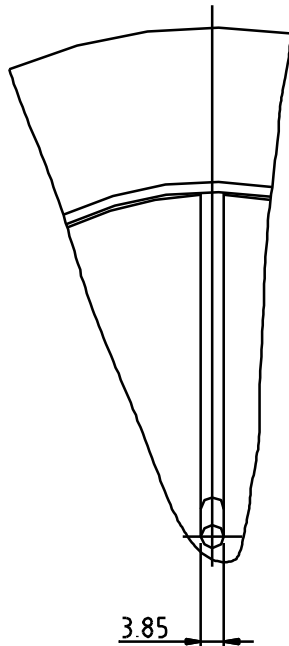
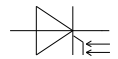

Kriechstrecke : 49mm
Anpresskraft: 90 - 130 kN

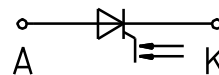

Lichtgezündeter Netz Thyristor
mit integriertem Überspannungsschutz

T 2563 N 75 TOH

Phase Control Thyristor, light triggered
with integrated overvoltage protection

Vorläufige Daten / Provisional Data

N

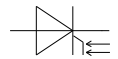

Durchlaßkennlinien $i_T = f(v_T)$
Limiting and typical on-state characteristic

$t_{vj} = 120^\circ\text{C}$

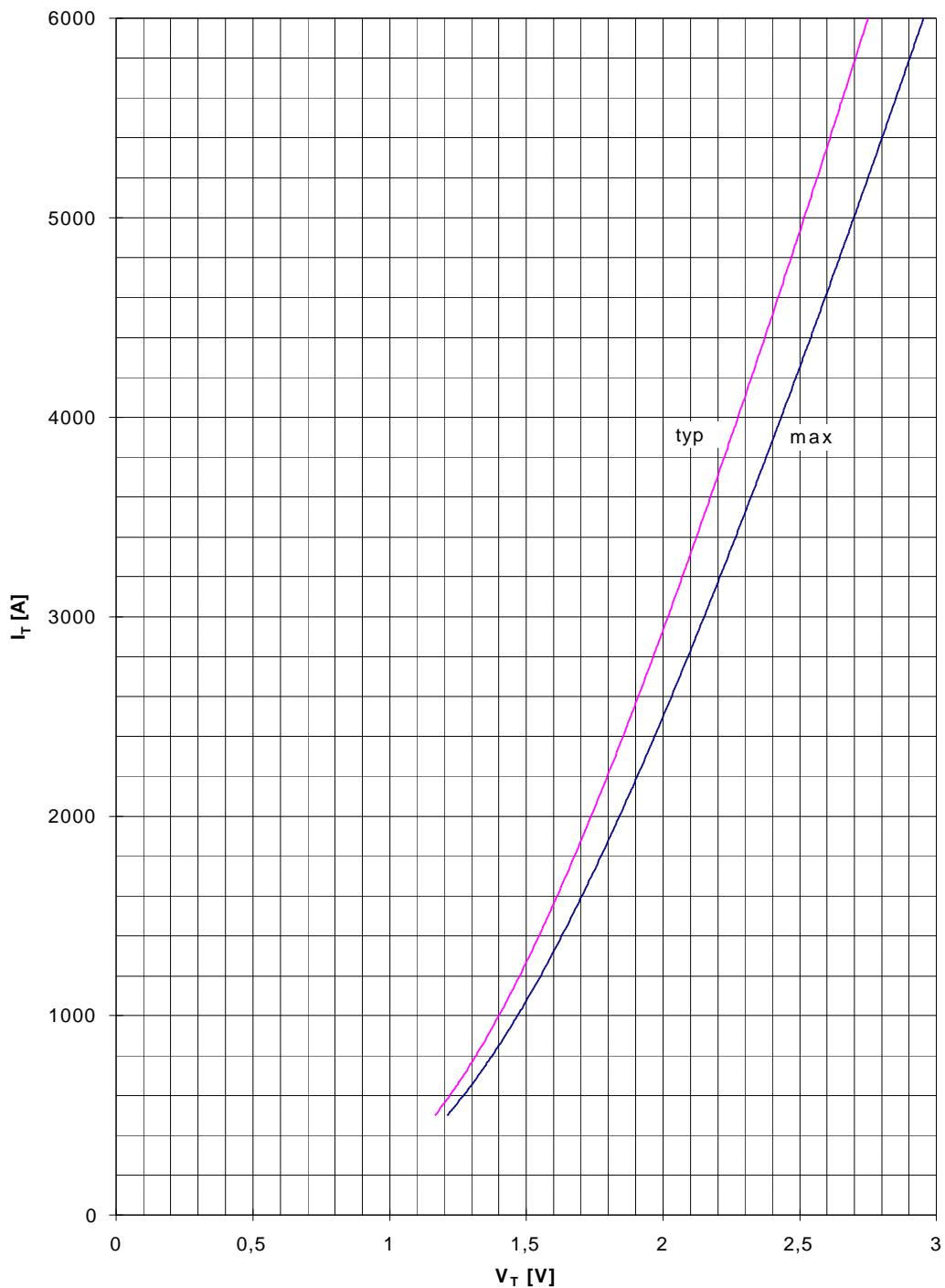

Lichtgezündeter Netz Thyristor
mit integriertem. Überspannungsschutz

T 2563 N 75 TOH

Phase Control Thyristor, light triggered
with integrated overvoltage protection

Vorläufige Daten / Provisional Data

N

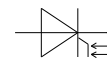

Sperrverzögerungsladung $Q_{rr} = f(-di/dt)$
recovered charge

Nebenbedingungen: $t_{vj} = 120^{\circ}\text{C}$, $I_{TM} = 4000\text{A}$, $v_R = 0,5 \cdot V_{RRM}$, $v_{RM} = 0,8 \cdot V_{RRM}$

