

European Power-Semiconductor and Electronics Company GmbH + Co. KG

Leistungsgleichrichterdioden Power Rectifier Diodes D 2659 N

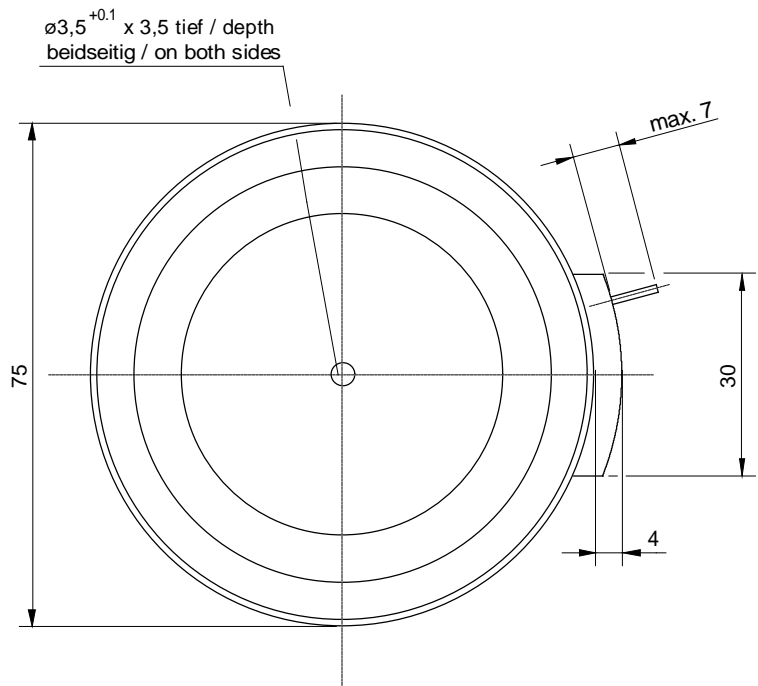
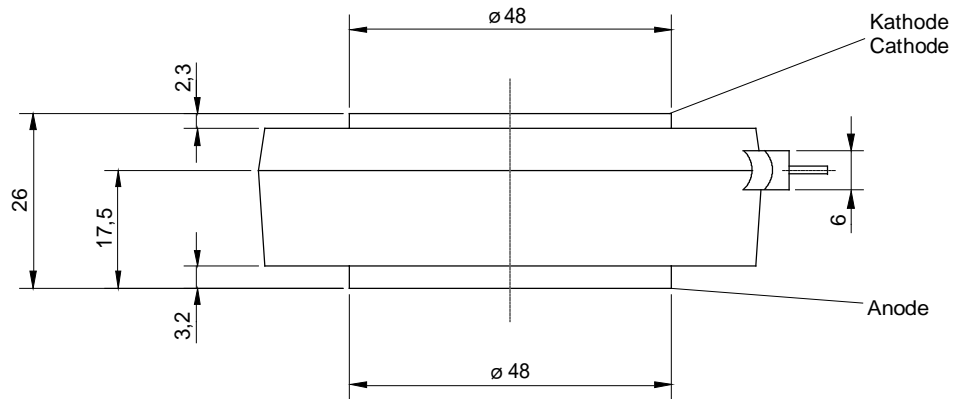

D 2659 N

Elektrische Eigenschaften

Electrical properties

Höchstzulässige Werte

Maximum rated values

Periodische Spitzensperrspannung	repetitive peak reverse voltage	$t_{vj} = -40^{\circ}\text{C} \dots t_{vj \text{ max}}$	V_{RRM}	2000, 2200	V
				2400	V
Stoßspitzensperrspannung	non-repetitive peak reverse voltage	$t_{vj} = +25^{\circ}\text{C} \dots t_{vj \text{ max}}$	$V_{RSM} = V_{RRM}$	+ 100	V
Durchlaßstrom-Grenzeffektivwert	RMS forward current		I_{FRMSM}	4,71	kA
Dauergrenzstrom	mean forward current	$t_c = 100^{\circ}\text{C}$	I_{FAVM}	2,65	kA
		$t_c = 83^{\circ}\text{C}$		3	kA
Stoßstrom-Grenzwert	surge forward current	$t_{vj} = 25^{\circ}\text{C}, t_p = 10 \text{ ms}$	I_{FSM}	41	kA ¹⁾
		$t_{vj} = t_{vj \text{ max}}, t_p = 10 \text{ ms}$		335	kA
Grenzlastintegral	$I^2 t$ -value	$t_{vj} = 25^{\circ}\text{C}, t_p = 10 \text{ ms}$	$I^2 t$	8405	kA ² s
		$t_{vj} = t_{vj \text{ max}}, t_p = 10 \text{ ms}$		5611	kA ² s

Charakteristische Werte

Characteristic values

Durchlaßspannung	on-state voltage	$t_{vj} = t_{vj \text{ max}}, I_F = 9 \text{ kA}$	V_T	max.	2,25	V
Schleusenspannung	threshold voltage	$t_{vj} = t_{vj \text{ max}}$	$V_{T(TO)}$		0,82	V
Ersatzwiderstand	slope resistance	$t_{vj} = t_{vj \text{ max}}$	r_T		0,148	mΩ
Sperrstrom	reverse current	$t_{vj} = t_{vj \text{ max}}, V_R = V_{RRM}$	I_R	max.	200	mA

Thermische Eigenschaften

Thermal properties

Innerer Widerstand	thermal resistance, junction to case	beidseitig/two-sided, $\Theta = 180^{\circ} \text{ sin}$	R_{thJC}	max.	0,0169	$^{\circ}\text{C/W}$
		beidseitig/two sided, DC		max.	0,0160	$^{\circ}\text{C/W}$
		Anode/anode, $\Theta = 180^{\circ} \text{ sin}$		max.	0,0329	$^{\circ}\text{C/W}$
		Anode/anode, DC		max.	0,0320	$^{\circ}\text{C/W}$
		Kathode/cathode, $\Theta = 180^{\circ} \text{ sin}$		max.	0,0329	$^{\circ}\text{C/W}$
		Kathode/cathode, DC		max.	0,0320	$^{\circ}\text{C/W}$
Übergangs-Wärmewiderstand	thermal resistance, case to heatsink	beidseitig /two-sided	R_{thCK}	max.	0,0025	$^{\circ}\text{C/W}$
		einseitig /single-sided		max.	0,0050	$^{\circ}\text{C/W}$
Höchstzul.Sperrschichttemperatur	max. junction temperature		$t_{vj \text{ max}}$		180	$^{\circ}\text{C}$
Betriebstemperatur	operating temperature		$t_{c \text{ op}}$		-40...+150	$^{\circ}\text{C}$
Lagertemperatur	storage temperature		t_{stg}		-40...+150	$^{\circ}\text{C}$

Mechanische Eigenschaften

Mechanical properties

Si-Element mit Druckkontakt	Si-pellet with pressure contact	$\varnothing = 56 \text{ mm}$				
Anpreßkraft	clamping force	Gehäuseform/case design T	F		24...60	kN
Gewicht	weight		G	typ.	540	g
Kriechstrecke	creepage distance				40	mm
Feuchteklasse	humidity classification	DIN 40040				C
Schwingfestigkeit	vibration resistance	$f = 50 \text{ Hz}$			50	m/s ²
Maßbild	outline					Seite/page

¹⁾ Gehäusegrenzstrom 32 kA (50 Hz Sinushalbwellen) / Current limit of case 32 kA (50 Hz sinusoidal half-wave)

D 2659 N

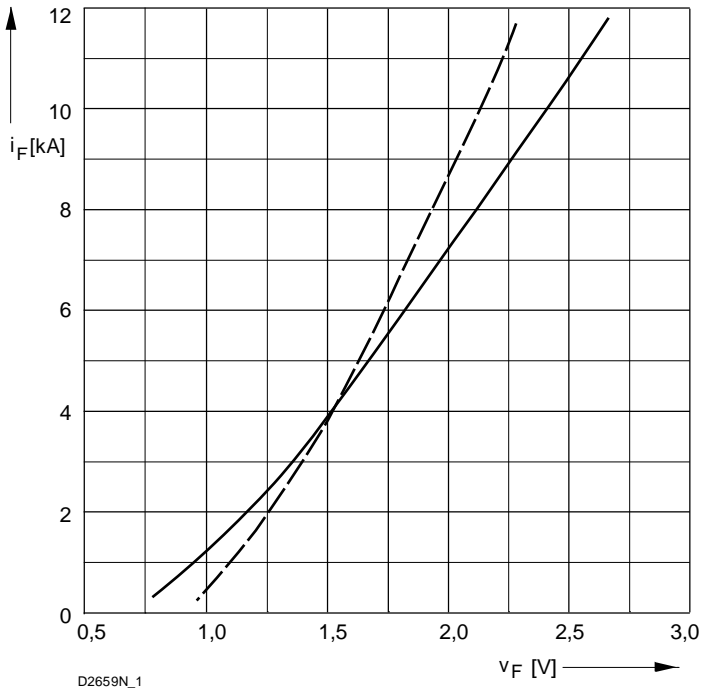

D2659N_1

Bild/ Fig. 1
Grenzdurchlaßkennlinie
Limiting forward characteristic $i_F = f(v_F)$
— $t_{vj} = 180\text{ °C}$
- - - $t_{vj} = 25\text{ °C}$

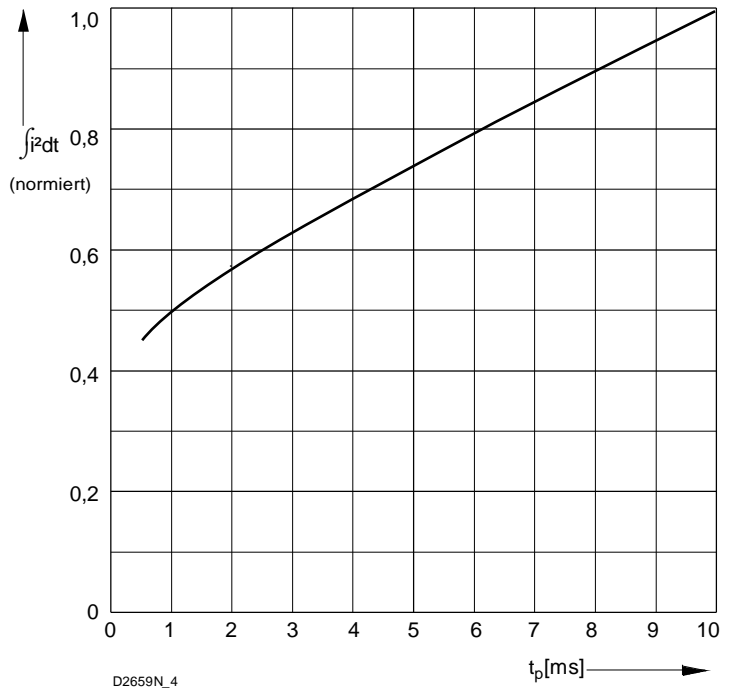

D2659N_4

Bild / Fig. 2
Normiertes Grenzlastintegral / Normalized i^2t
 $\int i^2 dt = f(t_p)$

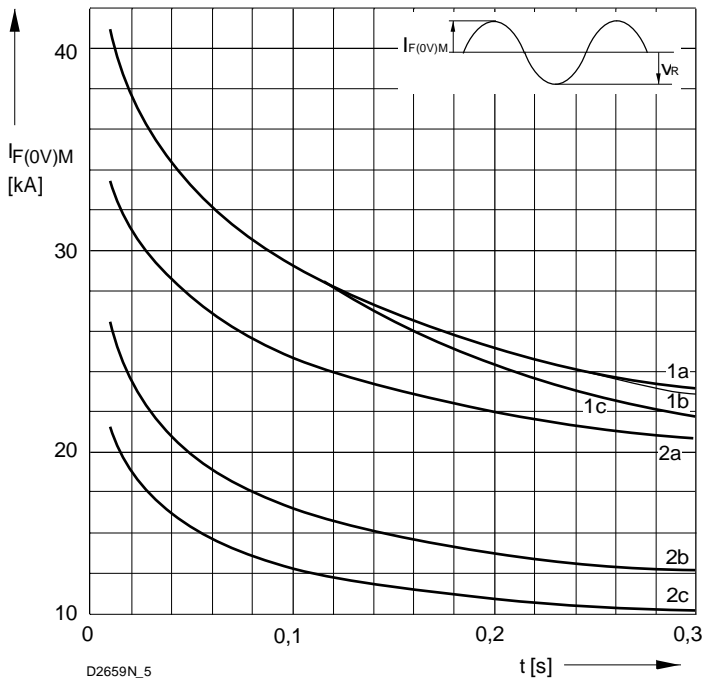

D2659N_5

Bild / Fig. 3
Grenzstrom / Maximum overload forward current $I_{F(0V)M} = f(t)$
1 - $I_{FAV(vor)} = 0\text{ A}$; $t_{vj} = t_c = 25\text{ °C}$
2 - $I_{FAV(vor)} = 2650\text{ A}$; $t_c = 100\text{ °C}$; $t_{vj} = 180\text{ °C}$
a - $v_R \leq 50\text{ V}$
b - $v_R = 0,5 V_{RRM}$
c - $v_R = 0,8 V_{RRM}$

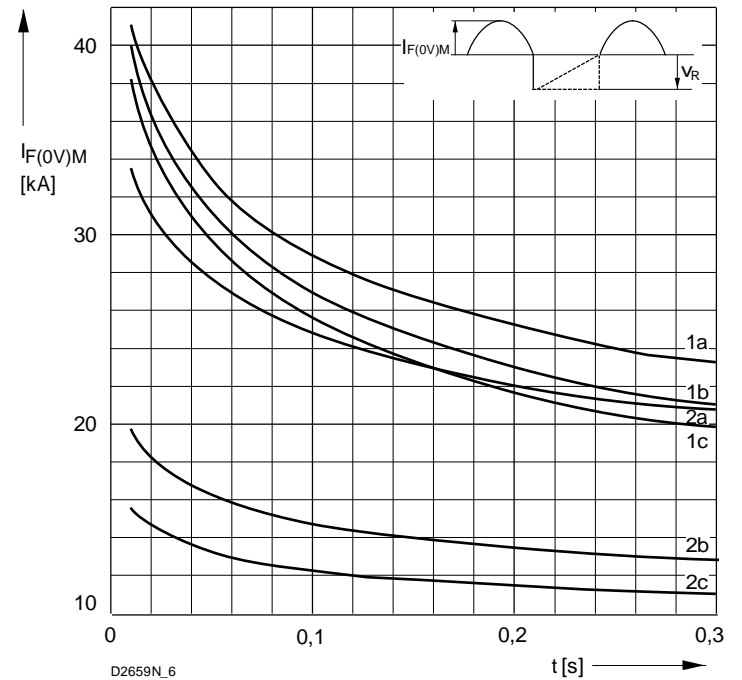

D2659N_6

Bild / Fig. 4
Grenzstrom / Maximum overload forward current $I_{F(0V)M} = f(t)$
1 - $I_{FAV(vor)} = 0\text{ A}$; $t_{vj} = t_c = 25\text{ °C}$
2 - $I_{FAV(vor)} = 2650\text{ A}$; $t_c = 100\text{ °C}$; $t_{vj} = 180\text{ °C}$
a - $v_R \leq 50\text{ V}$
b - $v_R = 0,5 V_{RRM}$
c - $v_R = 0,8 V_{RRM}$

D 2659 N



Bild / Fig. 5
 Differenz zwischen den Wärmewiderständen für Pulsstrom und DC
 Difference between the values of thermal resistance for pulse current and DC
 Parameter: Stromkurvenform / Current waveform



Bild / Fig. 6
 Sperrverzögerungsladung / Recovered charge $Q_r = f(-di_F/dt)$
 $t_{vj} = t_{vjmax}$; $V_R \leq 0,5 V_{RRM}$; $V_{RM} = 0,8 V_{RRM}$
 Beschaltung / Snubber: $C = 1,5 \mu F$; $R = 2,7 \Omega$
 Parameter: Durchlaßstrom / Forward current i_{FM}

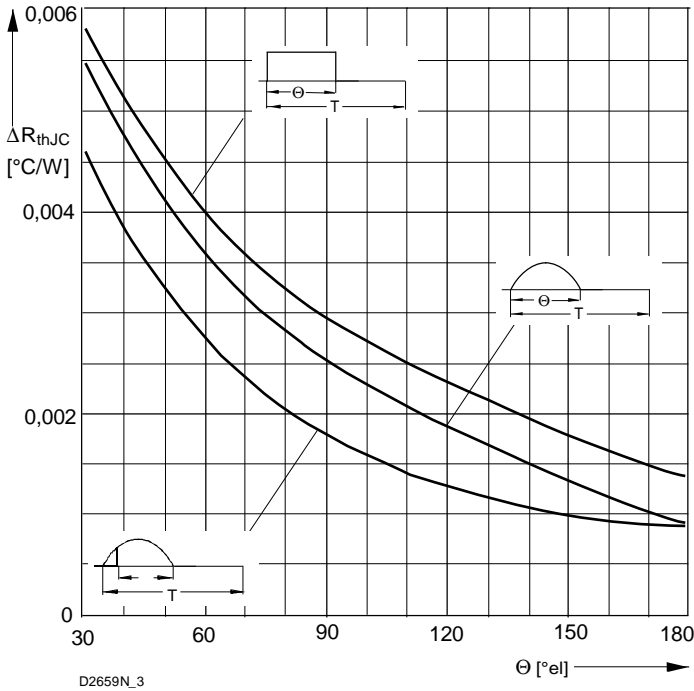

Bild / Fig. 7
 Transienter innerer Wärmewiderstand
 Transient thermal impedance $Z_{thJC} = f(t)$, DC
 1 - Beidseitige Kühlung / Two-sided cooling
 2 - Anodenseitige Kühlung / Anode-sided cooling
 3 - Kathodenseitige Kühlung / Cathode-sided cooling

Analytische Elemente des transienten Wärmewiderstandes Z_{thJC} für DC
 Analytical elements of transient thermal impedance Z_{thJC} for DC

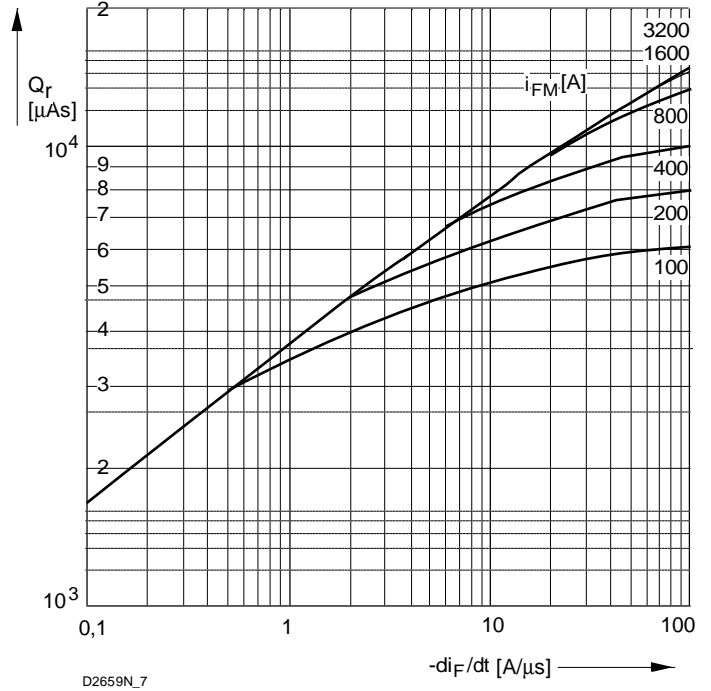
Kühlg. Cooling	Pos. n	1	2	3	4	5	6	7
1	$R_{thn} \text{ } ^\circ\text{C/W}$	0,000037	0,000393	0,00138	0,00177	0,00503	0,00739	
	$\tau_n \text{ [s]}$	0,000204	0,00118	0,0103	0,0542	0,219	1,15	
2	$R_{thn} \text{ } ^\circ\text{C/W}$	0,000042	0,000578	0,00184	0,00617	0,00487	0,0185	
	$\tau_n \text{ [s]}$	0,000193	0,00166	0,0161	0,164	2,46	6,11	
3	$R_{thn} \text{ } ^\circ\text{C/W}$	0,000042	0,000578	0,00184	0,00617	0,00487	0,0185	
	$\tau_n \text{ [s]}$	0,000193	0,00166	0,0161	0,164	2,46	6,11	

- 1 - Beidseitige Kühlung / Two-sided cooling
- 2 - Anodenseitige Kühlung / Anode-sided cooling
- 3 - Kathodenseitige Kühlung / Cathode-sided cooling

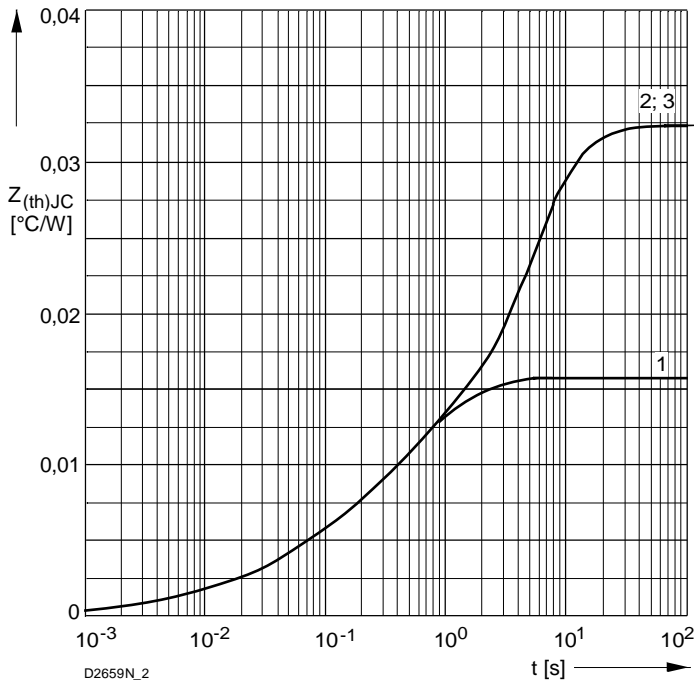
Analytische Funktion / Analytical function

$$Z_{thJC} = \sum_{n=1}^{n_{max}} R_{thn} (1 - \text{EXP}(-t/\tau_n))$$