

Technische Information / Technical Information

IGBT-Module
IGBT-Modules

FZ 1600 R 12 KL4C

eupec



vorläufige Daten
preliminary data

Höchstzulässige Werte / Maximum rated values

Elektrische Eigenschaften / Electrical properties

Kollektor-Emitter-Sperrspannung collector-emitter voltage		V_{CES}	1200	V
Kollektor-Dauergleichstrom DC-collector current	$T_C = 80^\circ\text{C}$	$I_{C,nom.}$	1600	A
	$T_C = 25^\circ\text{C}$	I_C	2450	A
Periodischer Kollektor Spitzenstrom repetitive peak collector current	$t_p = 1\text{ ms}, T_C = 80^\circ\text{C}$	I_{CRM}	3200	A
Gesamt-Verlustleistung total power dissipation	$T_C = 25^\circ\text{C}, \text{Transistor}$	P_{tot}	10,0	kW
Gate-Emitter-Spitzenspannung gate-emitter peak voltage		V_{GES}	+/- 20V	V
Dauergleichstrom DC forward current		I_F	1600	A
Periodischer Spitzenstrom repetitive peak forw. current	$t_p = 1\text{ ms}$	I_{FRM}	3200	A
Grenzlastintegral der Diode I^2t - value, Diode	$V_R = 0V, t_p = 10\text{ms}, T_{vj} = 125^\circ\text{C}$	I^2t	590	kA^2s
Isolations-Prüfspannung insulation test voltage	RMS, $f = 50\text{ Hz}, t = 1\text{ min.}$	V_{ISOL}	2,5	kV

Charakteristische Werte / Characteristic values

Transistor / Transistor

			min.	typ.	max.	
Kollektor-Emitter Sättigungsspannung collector-emitter saturation voltage	$I_C = 1600A, V_{GE} = 15V, T_{vj} = 25^\circ\text{C}$	$V_{CE\text{ sat}}$	-	2,1	2,6	V
	$I_C = 1600A, V_{GE} = 15V, T_{vj} = 125^\circ\text{C}$		-	2,4		V
Gate-Schwellenspannung gate threshold voltage	$I_C = 64\text{mA}, V_{CE} = V_{GE}, T_{vj} = 25^\circ\text{C}$	$V_{GE(th)}$	4,5	5,5	6,5	V
Eingangskapazität input capacitance	$f = 1\text{MHz}, T_{vj} = 25^\circ\text{C}, V_{CE} = 25V, V_{GE} = 0V$	C_{ies}	-	110	-	nF
Kollektor-Emitter Reststrom collector-emitter cut-off current	$V_{CE} = 1200V, V_{GE} = 0V, T_{vj} = 25^\circ\text{C}$	I_{CES}	-	0,04	1	mA
	$V_{CE} = 1200V, V_{GE} = 0V, T_{vj} = 125^\circ\text{C}$		-	3,5		mA
Gate-Emitter Reststrom gate-emitter leakage current	$V_{CE} = 0V, V_{GE} = 20V, T_{vj} = 25^\circ\text{C}$	I_{GES}	-	-	600	nA

prepared by: Mark Münzer	date of publication: 1999-03-11
approved by: Jens Thureau	revision: 1b

Technische Information / Technical Information

IGBT-Module
IGBT-Modules

FZ 1600 R 12 KL4C

eupec



vorläufige Daten preliminary data

Charakteristische Werte / Characteristic values

Transistor / Transistor		min.	typ.	max.		
Einschaltverzögerungszeit (ind. Last) turn on delay time (inductive load)	$I_C = 1600A, V_{CE} = 600V$	$t_{d,on}$	-	0,28	-	μs
	$V_{GE} = \pm 15V, R_G = 0,91\Omega, T_{vj} = 25^\circ C$					
	$V_{GE} = \pm 15V, R_G = 0,91\Omega, T_{vj} = 125^\circ C$					
Anstiegszeit (induktive Last) rise time (inductive load)	$I_C = 1600A, V_{CE} = 600V$	t_r	-	0,19	-	μs
	$V_{GE} = \pm 15V, R_G = 0,91\Omega, T_{vj} = 25^\circ C$					
	$V_{GE} = \pm 15V, R_G = 0,91\Omega, T_{vj} = 125^\circ C$					
Abschaltverzögerungszeit (ind. Last) turn off delay time (inductive load)	$I_C = 1600A, V_{CE} = 600V$	$t_{d,off}$	-	1,06	-	μs
	$V_{GE} = \pm 15V, R_G = 0,91\Omega, T_{vj} = 25^\circ C$					
	$V_{GE} = \pm 15V, R_G = 0,91\Omega, T_{vj} = 125^\circ C$					
Fallzeit (induktive Last) fall time (inductive load)	$I_C = 1600A, V_{CE} = 600V$	t_f	-	0,14	-	μs
	$V_{GE} = \pm 15V, R_G = 0,91\Omega, T_{vj} = 25^\circ C$					
	$V_{GE} = \pm 15V, R_G = 0,91\Omega, T_{vj} = 125^\circ C$					
Einschaltverlustenergie pro Puls turn-on energy loss per pulse	$I_C = 1600A, V_{CE} = 600V, V_{GE} = 15V$ $R_G = 0,91\Omega, T_{vj} = 125^\circ C, L_S = 70nH$	E_{on}	-	210	-	mWs
Abschaltverlustenergie pro Puls turn-off energy loss per pulse	$I_C = 1600A, V_{CE} = 600V, V_{GE} = 15V$ $R_G = 0,91\Omega, T_{vj} = 125^\circ C, L_S = 70nH$	E_{off}	-	260	-	mWs
Kurzschlußverhalten SC Data	$t_p \leq 10\mu sec, V_{GE} \leq 15V, R_G = 0,91\Omega$ $T_{vj} \leq 125^\circ C, V_{CC} = 900V, V_{CEmax} = V_{CES} - L_{sCE} \cdot di/dt$	I_{SC}	-	12000	-	A
Modulinduktivität stray inductance module		L_{sCE}	-	15	-	nH
Modul Leitungswiderstand, Anschlüsse – Chip module lead resistance, terminals – chip	$T_C = 25^\circ C$	R_{CC+EE}	-	0,10	-	m Ω

Charakteristische Werte / Characteristic values

Diode / Diode		min.	typ.	max.		
Durchlaßspannung forward voltage	$I_F = 1600A, V_{GE} = 0V, T_{vj} = 25^\circ C$	V_F	-	1,8	2,3	V
	$I_F = 1600A, V_{GE} = 0V, T_{vj} = 125^\circ C$					
Rückstromspitze peak reverse recovery current	$I_F = 1600A, -di_F/dt = 9000A/\mu sec$	I_{RM}	-	900	-	A
	$V_R = 600V, V_{GE} = -15V, T_{vj} = 25^\circ C$					
	$V_R = 600V, V_{GE} = -15V, T_{vj} = 125^\circ C$					
Sperrverzögerungsladung recovered charge	$I_F = 1600A, -di_F/dt = 9000A/\mu sec$	Q_r	-	150	-	μAs
	$V_R = 600V, V_{GE} = -15V, T_{vj} = 25^\circ C$					
	$V_R = 600V, V_{GE} = -15V, T_{vj} = 125^\circ C$					
Abschaltenergie pro Puls reverse recovery energy	$I_F = 1600A, -di_F/dt = 9000A/\mu sec$	E_{rec}	-	60	-	mWs
	$V_R = 600V, V_{GE} = -15V, T_{vj} = 25^\circ C$					
	$V_R = 600V, V_{GE} = -15V, T_{vj} = 125^\circ C$					

Technische Information / Technical Information

IGBT-Module
IGBT-Modules

FZ 1600 R 12 KL4C

eupec

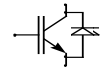

vorläufige Daten preliminary data

Thermische Eigenschaften / Thermal properties

			min.	typ.	max.	
Innerer Wärmewiderstand thermal resistance, junction to case	Transistor / transistor, DC	R_{thJC}	-	-	0,0125	K/W
	Diode/Diode, DC		-	-	0,0210	K/W
Übergangs-Wärmewiderstand thermal resistance, case to heatsink	pro Modul / per module $d_{Paste} \leq 100\mu m$ / $d_{grease} \leq 100\mu m$	R_{thCK}	-	0,008	-	K/W
Höchstzulässige Sperrschichttemperatur maximum junction temperature		T_{vj}	-	-	150	°C
Betriebstemperatur operation temperature		T_{op}	-40	-	125	°C
Lagertemperatur storage temperature		T_{stg}	-40	-	125	°C

Mechanische Eigenschaften / Mechanical properties

Gehäuse, siehe Anlage case, see appendix						
Innere Isolation internal insulation				Al_2O_3		
Kriechstrecke creepage distance				17		mm
Luftstrecke clearance				10		mm
CTI comperative tracking index				275		
Anzugsdrehmoment f. mech. Befestigung mounting torque		M1	4,25	5	5,75	Nm
Anzugsdrehmoment f. elektr. Anschlüsse terminal connection torque	terminals M4	M2	1,7	2	2,3	Nm
	terminals M8		8		10	Nm
Gewicht weight		G		1500		g

Mit dieser technischen Information werden Halbleiterbauelemente spezifiziert, jedoch keine Eigenschaften zugesichert. Sie gilt in Verbindung mit den zugehörigen Technischen Erläuterungen.

This technical information specifies semiconductor devices but promises no characteristics. It is valid in combination with the belonging technical notes.

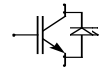

Ausgangskennlinie (typisch)
Output characteristic (typical)

$I_C = f(V_{CE})$
 $V_{GE} = 15V$

vorläufige Daten
preliminary data

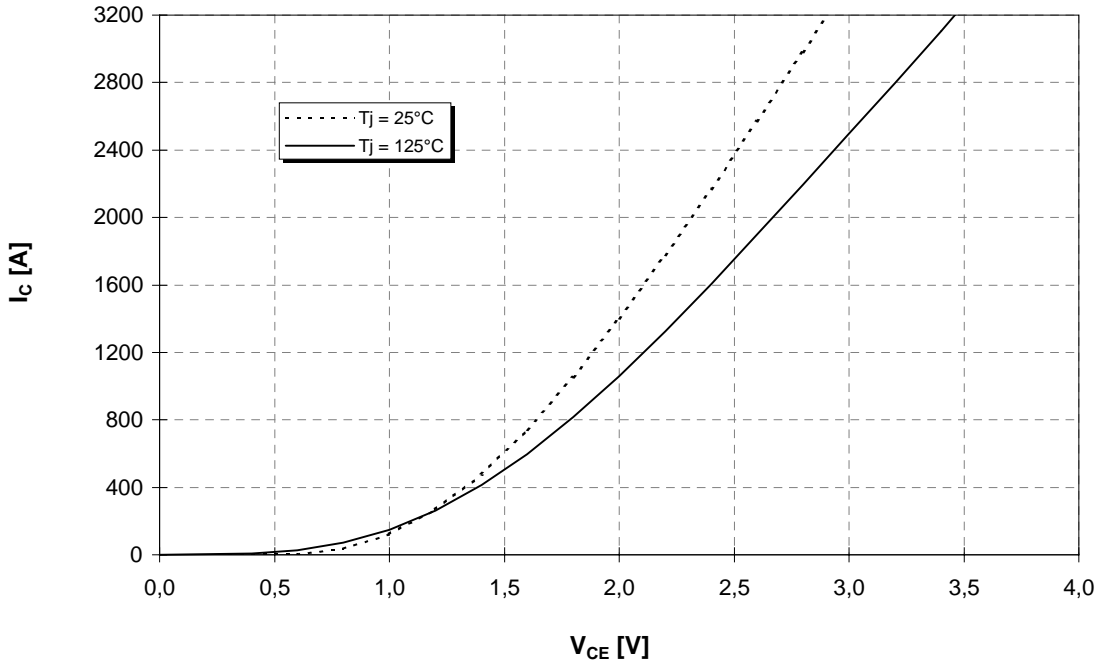

Ausgangskennlinienfeld (typisch)
Output characteristic (typical)

$I_C = f(V_{CE})$
 $T_{vj} = 125°C$

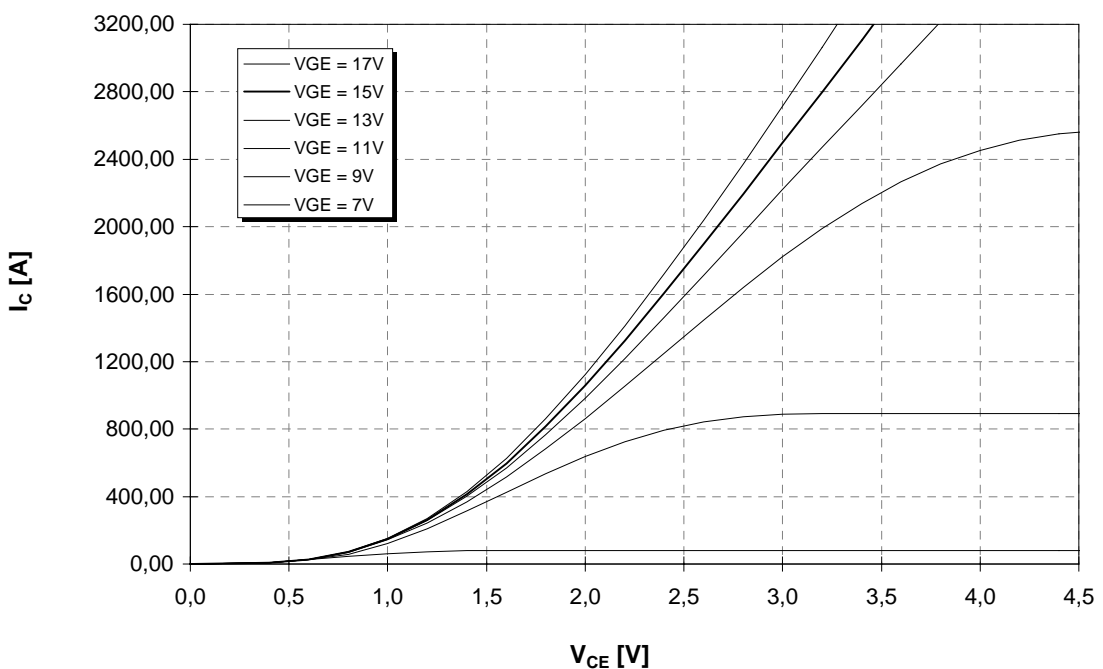

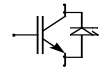

vorläufige Daten
preliminary data

Übertragungscharakteristik (typisch)
Transfer characteristic (typical)

$I_C = f(V_{GE})$
 $V_{CE} = 20V$

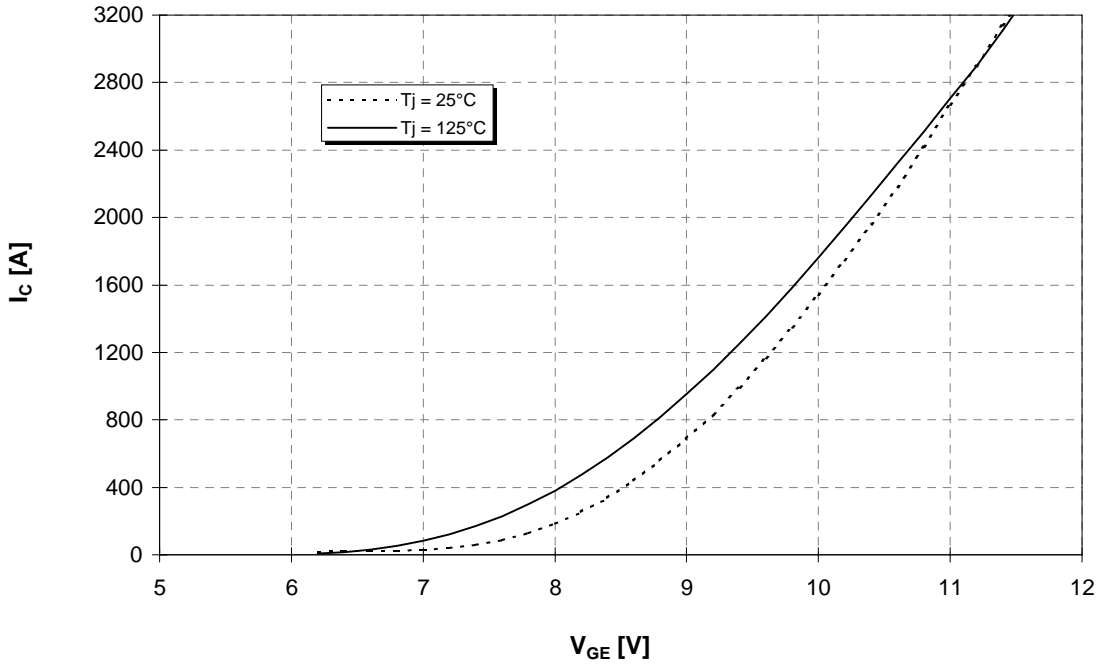

Durchlaßkennlinie der Inversdiode (typisch)
Forward characteristic of inverse diode (typical)

$I_F = f(V_F)$

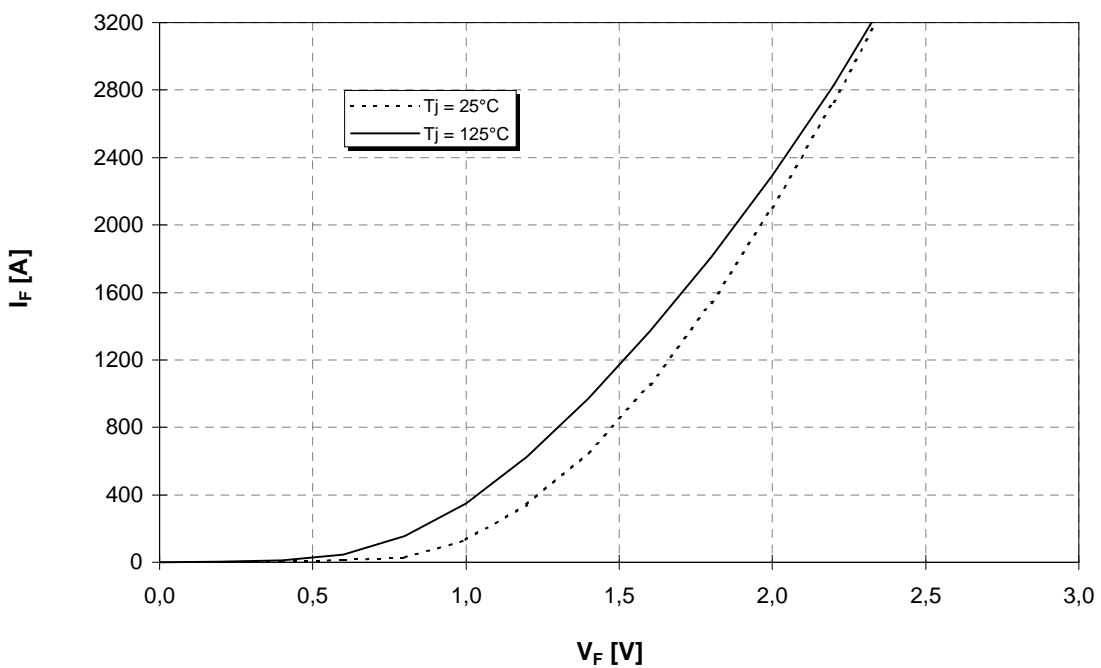

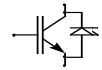

vorläufige Daten
preliminary data

Schaltverluste (typisch) $E_{on} = f(I_C)$, $E_{off} = f(I_C)$, $E_{rec} = f(I_C)$
Switching losses (typical) $R_{gon} = R_{goff} = 0,91 \Omega$, $V_{CE} = 600V$, $T_J = 125^\circ C$

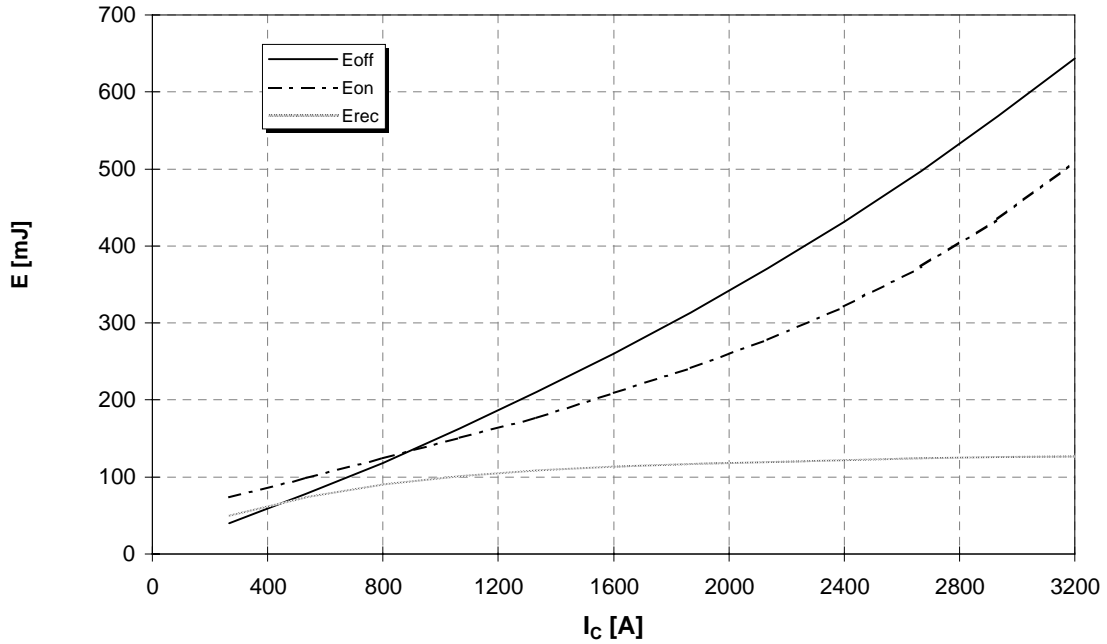

Schaltverluste (typisch) $E_{on} = f(R_G)$, $E_{off} = f(R_G)$, $E_{rec} = f(R_G)$
(R_G)

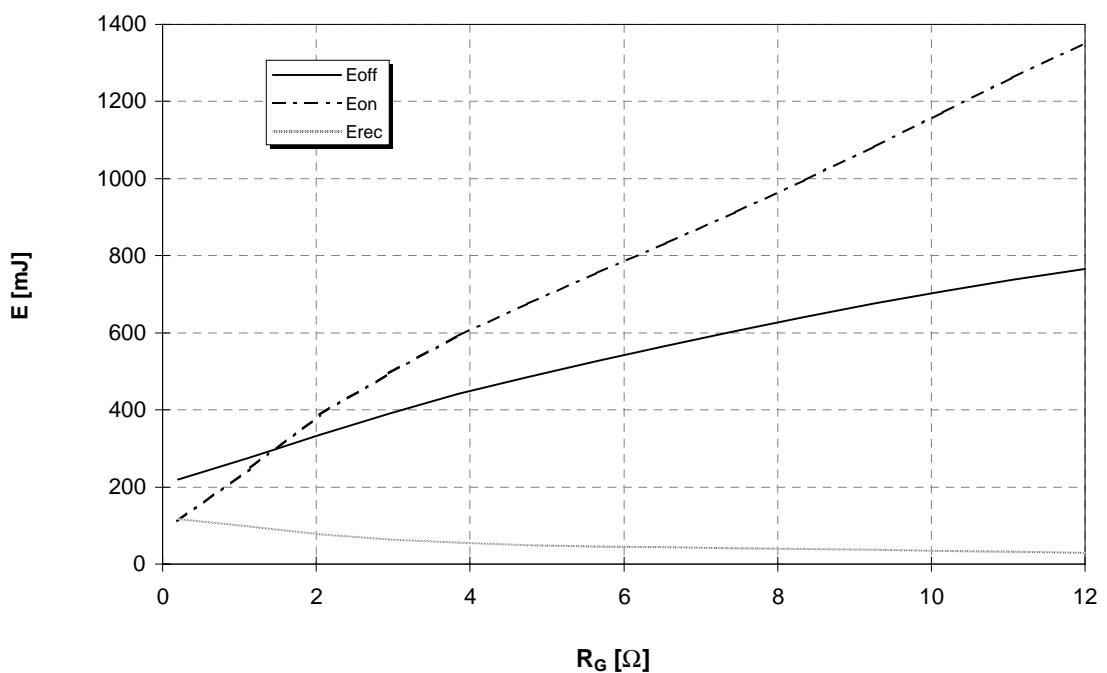



vorläufige Daten

preliminary data

Transienter Wärmewiderstand
Transient thermal impedance

$$Z_{thJC} = f(t)$$

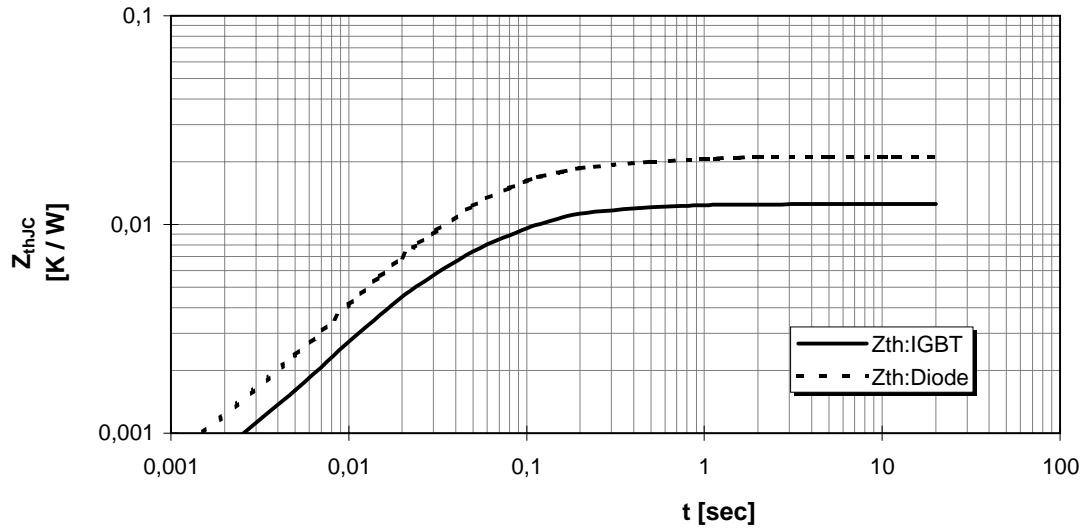

i	1	2	3	4
r_i [K/kW] : IGBT	0,21	3,98	7,32	0,99
τ_i [sec] : IGBT	0,00006	0,0187	0,080	0,50
r_i [K/kW] : Diode	0,32	4,70	2,93	13,05
τ_i [sec] : Diode	0,00014	0,0218	0,060	0,50

Sicherer Arbeitsbereich (RBSOA)

Reverse bias safe operation area (RBSOA)

$$R_g = 0,91\Omega, T_{vj} = 125^\circ\text{C}$$

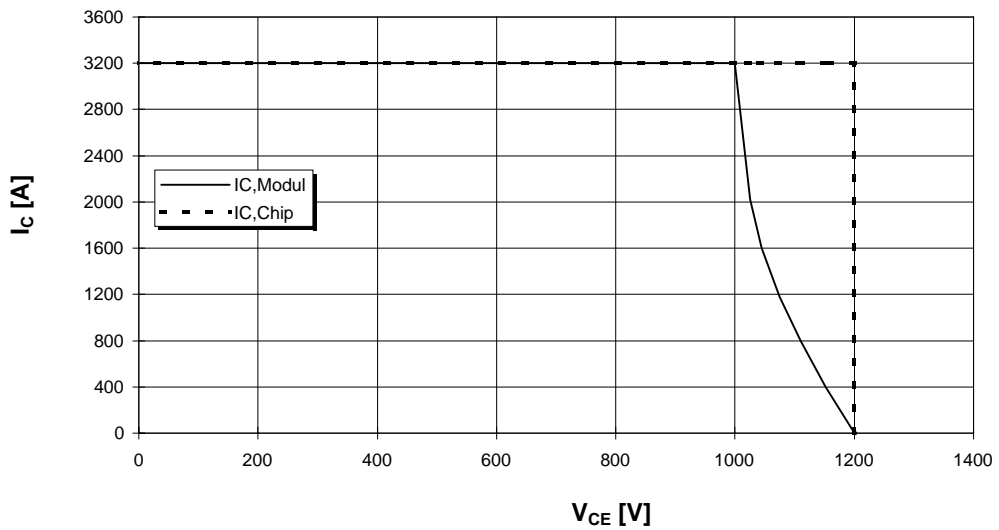

Technische Information / Technical Information

IGBT-Module
IGBT-Modules

FZ 1600 R 12 KL4C

eupec

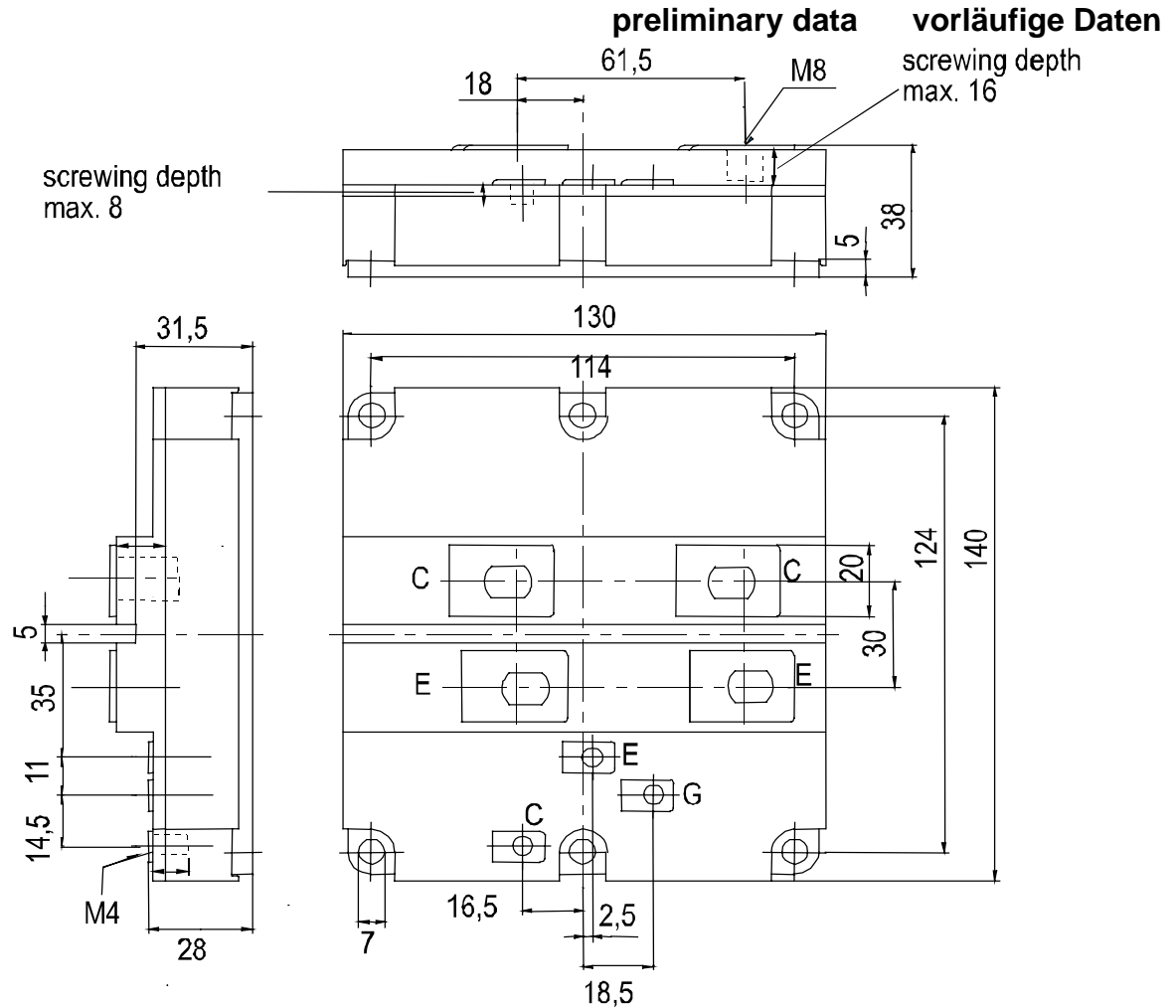
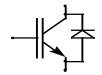

external connections (to be done)

