

European Power-Semiconductor and Electronics Company

Marketing Information

FD 400 R 33 KF1

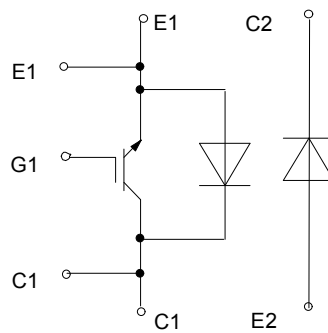
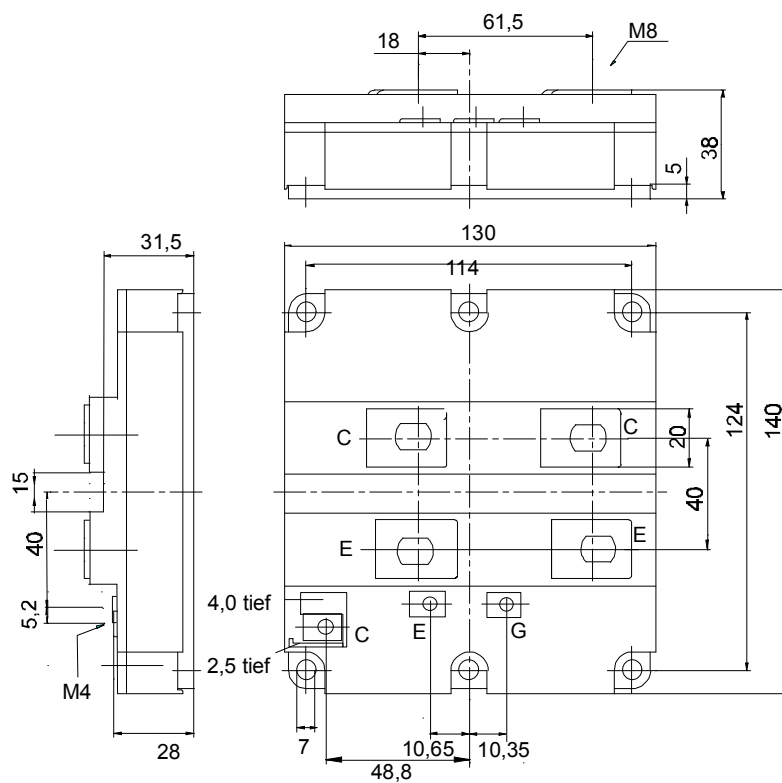

FD 400 R 33 KF1

Höchstzulässige Werte / Maximum rated values

Elektrische Eigenschaften / Electrical properties

Kollektor-Emitter-Sperrspannung	collector-emitter voltage	$t_{vj} = 25^\circ\text{C}$	V_{CES}	3300	V
Kollektor-Dauergleichstrom	DC-collector current		I_C	400	A
Period. Kollektor Spitzenstrom	repetitive peak collector current	$t_p = 1 \text{ ms}$	I_{CRM}	800	A
Gesamt-Verlustleistung	total power dissipation	$t_c = 25^\circ\text{C}$, Transistor / transistor	P_{tot}	4400	W
Gate-Emitter-Spitzenspannung	gate-emitter peak voltage		V_{GE}	+/- 20	V
Dauergleichstrom	DC forward current		I_F	400	A
Periodischer Spitzenstrom	repetitive peak forw. current	$t_p = 1 \text{ ms}$	I_{FRM}	800	A
Isolations-Prüfspannung	insulating test voltage	R_{MS} , $f = 50 \text{ Hz}$, $t = 1 \text{ min.}$	V_{ISOL}	5	kV

Charakteristische Werte / Characteristic values: Transistor

				min.	typ.	max.
Koll.-Emitter Gleichsperrspannung	coll.-emitter direct off-state voltage	$V_{GE} = -15\text{V}$, $t_c = -40^\circ\text{C} \dots +125^\circ\text{C}$	$V_{CE(D)}$	-	2100	-
Koll.-Emitter Sättigungsspannung	coll.-emitter saturation voltage	$i_C = 400 \text{ A}$, $v_{GE} = 15\text{V}$, $t_{vj} = 25^\circ\text{C}$	$V_{CE \text{ sat}}$	-	3,2	4,2
		$i_C = 400 \text{ A}$, $v_{GE} = 15\text{V}$, $t_{vj} = 125^\circ\text{C}$		-	4,0	-
Gate-Schwellenspannung	gate threshold voltage	$i_C = 400 \text{ A}$, $v_{CE} = v_{GE}$, $t_{vj} = 25^\circ\text{C}$	$V_{GE(th)}$	4,5	5,5	6,5
Eingangskapazität	input capacity	$f_0 = 1 \text{ MHz}$, $t_{vj} = 25^\circ\text{C}$ $v_{CE} = 25\text{V}$, $v_{GE} = 0 \text{ V}$	C_{ies}	-	40	-
Kollektor-Emitter Reststrom	collector-emitter cut-off current	$v_{CE} = 3300\text{V}$, $v_{GE} = 0\text{V}$, $t_{vj} = 25^\circ\text{C}$	i_{CES}	-	2	-
		$v_{CE} = 3300\text{V}$, $v_{GE} = 0\text{V}$, $t_{vj} = 125^\circ\text{C}$		-	25	-
Gate-Emitter Reststrom	gate leakage current	$v_{CE} = 0\text{V}$, $v_{GE} = 20\text{V}$, $t_{vj} = 25^\circ\text{C}$	i_{GES}	-	40	400
Emitter-Gate Reststrom	gate leakage current	$v_{CE} = 0\text{V}$, $v_{GE} = 20\text{V}$, $t_{vj} = 25^\circ\text{C}$	i_{EGS}	-	40	400
Einschaltzeit (induktive Last)	turn-on time (inductive load)	$i_C = 400\text{A}$, $v_{CE} = 1800\text{V}$, $v_L = \pm 15\text{V}$ $C_{GE} = 120\text{nF}$, $R_G = 5,6\Omega$, $t_{vj} = 25^\circ\text{C}$	t_{on}	-	1,2	-
		$C_{GE} = 120\text{nF}$, $R_G = 5,6\Omega$, $t_{vj} = 125^\circ\text{C}$		-	1,2	-
Speicherzeit (induktive Last)	storage time (inductive load)	$i_C = 400\text{A}$, $v_{CE} = 1800\text{V}$, $v_L = \pm 15\text{V}$ $C_{GE} = 120\text{nF}$, $R_G = 10\Omega$, $t_{vj} = 25^\circ\text{C}$	t_s	-	3,0	-
		$C_{GE} = 120\text{nF}$, $R_G = 10\Omega$, $t_{vj} = 125^\circ\text{C}$		-	3,4	-
Fallzeit (induktive Last)	fall time (inductive load)	$i_C = 400\text{A}$, $v_{CE} = 1800\text{V}$, $v_L = \pm 15\text{V}$ $C_{GE} = 120\text{nF}$, $R_G = 10\Omega$, $t_{vj} = 25^\circ\text{C}$	t_f	-	0,2	-
		$C_{GE} = 120\text{nF}$, $R_G = 10\Omega$, $t_{vj} = 125^\circ\text{C}$		-	0,2	-

Charakteristische Werte / Characteristic values: Transistor

Einschaltverlustleistung pro Puls	turn-on energy loss per pulse	$i_C = 400\text{A}$, $v_{CE} = 1800\text{V}$, $v_L = \pm 15\text{V}$ $C_{GE} = 120\text{nF}$, $R_G = 5,6\Omega$, $t_{vj} = 125^\circ\text{C}$	E_{on}	-	1,1	-
Abschaltverlustenergie pro Puls	turn-off energy loss per pulse	$i_C = 400\text{A}$, $v_{CE} = 1800\text{V}$, $v_L = \pm 15\text{V}$ $C_{GE} = 120\text{nF}$, $R_G = 10\Omega$, $t_{vj} = 125^\circ\text{C}$	E_{off}	-	0,7	-
Inversodiode / Inverse diode				min.	typ.	max.
Durchlaßspannung	forward voltage	$i_F = 400\text{A}$, $v_{GE} = 0 \text{ V}$, $t_{vj} = 25^\circ\text{C}$	v_F	-	2,7	3,5
		$i_F = 400\text{A}$, $v_{GE} = 0 \text{ V}$, $t_{vj} = 125^\circ\text{C}$		-	2,8	-
Rückstromspitze	peak reverse recovery current	$i_C = 400\text{A}$, $-di_F/dt = 1500 \text{ A}/\mu\text{s}$ $v_{RM} = 1800\text{V}$, $v_{EG} = 10\text{V}$, $t_{vj} = 25^\circ\text{C}$	I_{RM}	-	340	-
		$v_{RM} = 1800\text{V}$, $v_{EG} = 10\text{V}$, $t_{vj} = 125^\circ\text{C}$		-	400	-
Sperrverzögerungsladung	recovered charge	$i_F = 400\text{A}$, $-di_F/dt = 1500 \text{ A}/\mu\text{s}$ $v_{RM} = 1800\text{V}$, $v_{EG} = 10\text{V}$, $t_{vj} = 25^\circ\text{C}$	Q_f	-	300	-
		$v_{RM} = 1800\text{V}$, $v_{EG} = 10\text{V}$, $t_{vj} = 125^\circ\text{C}$		-	350	-

Thermische Eigenschaften / Thermal properties

Innerer Wärmewiderstand	thermal resist., junction to case	Transistor / transistor, DC Diode/diode, DC per module Diode/diode, DC per arm	R_{thJC}		0,028	$^\circ\text{C}/\text{W}$
					0,027	$^\circ\text{C}/\text{W}$
					0,054	$^\circ\text{C}/\text{W}$
Übergangs-Wärmewiderstand	thermal resist., case to heatsink	pro Modul / per Module pro Zweig / per arm	R_{thCK}	0,008	$^\circ\text{C}/\text{W}$	
				0,016	$^\circ\text{C}/\text{W}$	
Höchstzul. Sperrschichttemp.	max. junction temperature		$t_{vj \text{ max}}$		150	$^\circ\text{C}$
Betriebstemperatur	operating temperature		$t_{c \text{ op}}$		-40...+12	$^\circ\text{C}$
Lagertemperatur	storage temperature		t_{stg}		-40...+12	$^\circ\text{C}$

Mechanische Eigenschaften / Mechanical properties

Gehäuse	case					Seite 1
Innere Isolation	internal insulation					ALN
Anzugsdrehm. f. mech. Befest.	mounting torque	terminals M6/tolerance $\pm 10\%$	M1			5 Nm
Anzugsdrehm. f. elektr. Anschl.	terminal connection torque	terminals M4/tolerance +5/-10%	M2			2 Nm
		terminals M8				8...10 Nm
Gewicht	weight		G			1500 g

Mit dieser technischen Information werden Halbleiterbauelemente spezifiziert, jedoch keine Eigenschaften zugesichert. Sie gilt in Verbindung mit dem zugehörigen Technischen Erläuterungen. This technical information specifies semiconductor devices but promises no characteristics. It is valid in combination with the belonging technical notes.

Bedingungen für den Kurzschlußschutz / Conditions for short-circuit protection

$t_{IG} = 10 \mu\text{s}$

$v_L = \pm 15 \text{ V}$

$R_{GR} = 10 \Omega$, $C_{GE} = 120 \text{ nF}$

$t_{vj} = 125^\circ\text{C}$

$V_{CC} = 2100 \text{ V}$

$v_{CEM} = 2750 \text{ V}$

$i_{CMK1} \approx 2600 \text{ A}$

$i_{CMK2} \approx 2000 \text{ A}$

Unabhängig davon gilt bei abweichenden Bedingungen

with regard to other conditions

$v_{CEM} = v_{CES} - 20 \text{ nH x } |di_c/dt|$

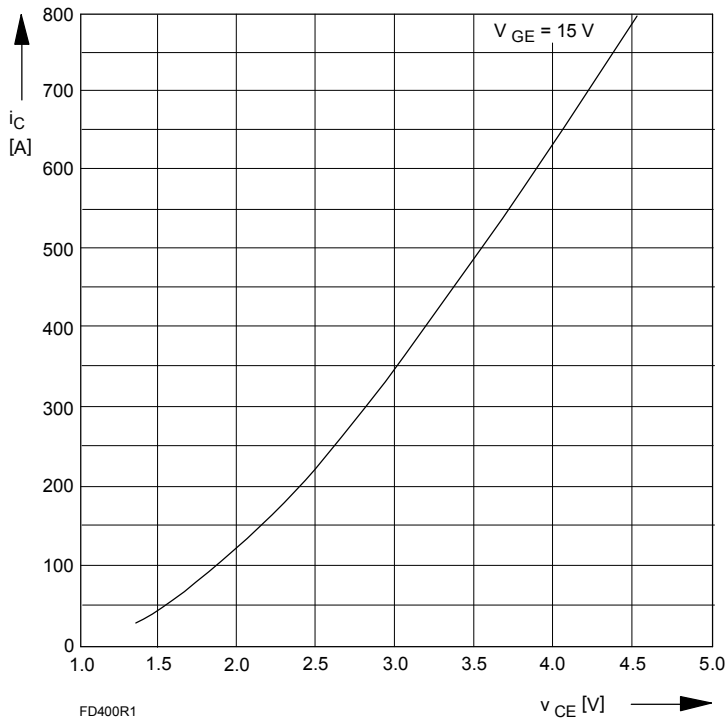

Bild/Fig. 1
 Kollektor-Emitter-Spannung im Sättigungsbereich (typisch)
 Collector-emitter-voltage in saturation region (typical)
 $t_{vj} = 25\text{ }^{\circ}\text{C}$

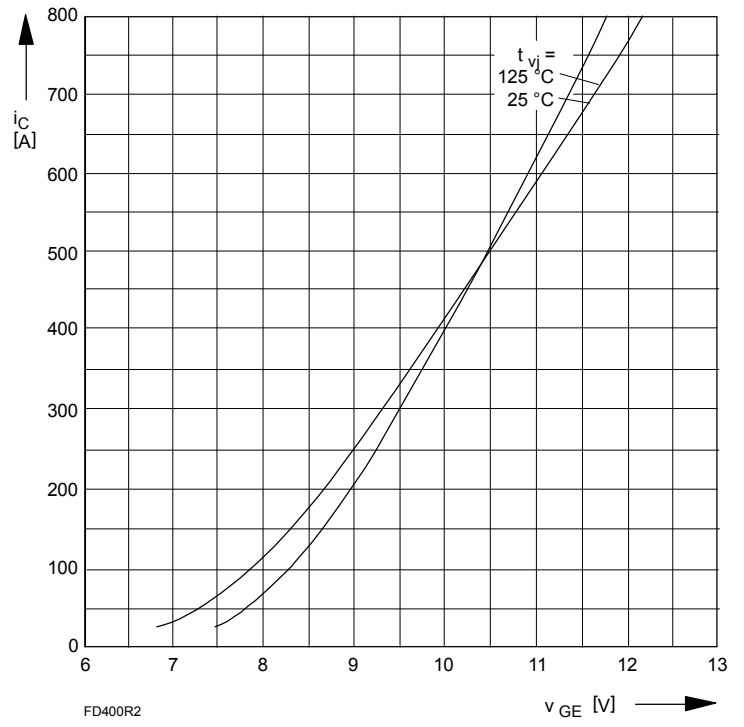

Bild/Fig. 2
 Übertragungscharakteristik (typisch)
 Transfer characteristic (typical)
 $V_{CE} = 20\text{ V}$

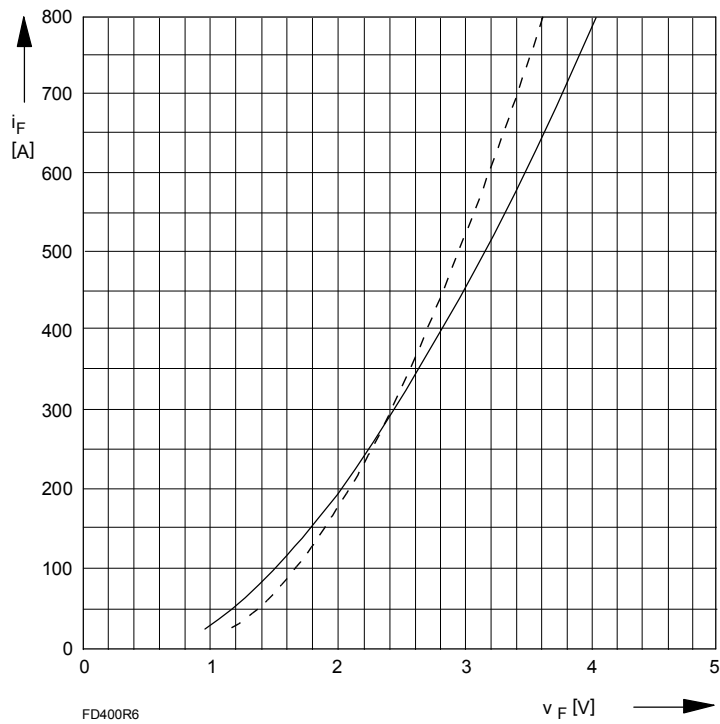

Bild/Fig. 6
 Durchlaßkennlinie der Inversdiode (typisch)
 Forward characteristic of the inverse diode (typical)
 ---- $t_{vj} = 25\text{ }^{\circ}\text{C}$
 — $t_{vj} = 125\text{ }^{\circ}\text{C}$