

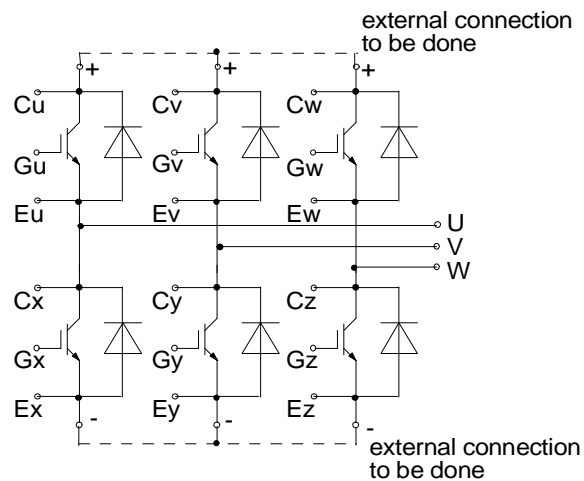

European Power-Semiconductor and Electronics Company GmbH + Co. KG

Marketing Information

FS 400 R 06 KF1

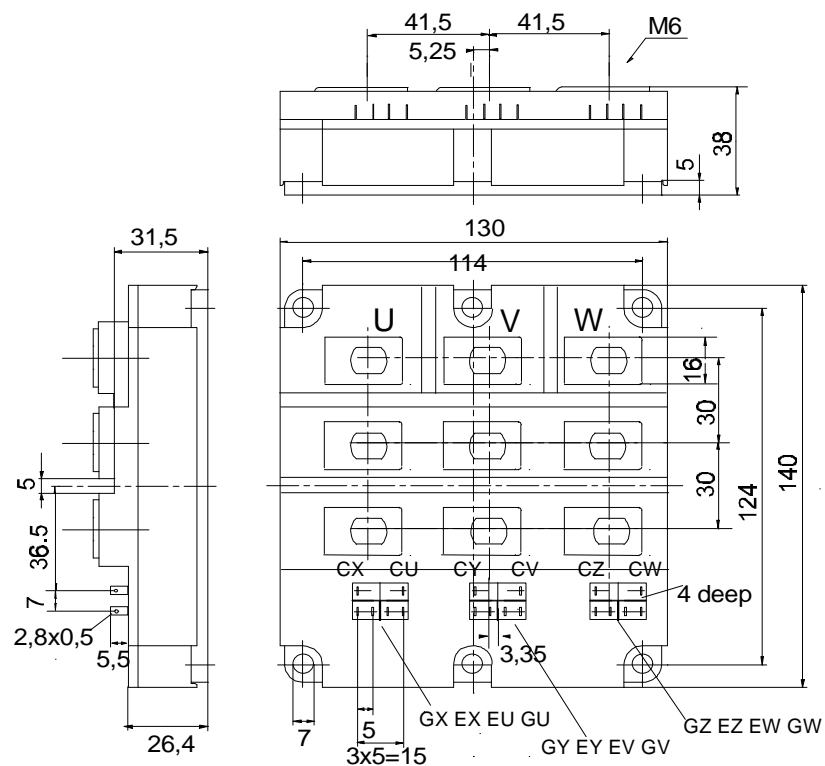

IGBT-Module

FS 400 R 06 KF1

Höchstzulässige Werte / Maximum rated values Elektrische Eigenschaften / Electrical properties

Vorläufige Daten
Preliminary Data

Kollektor-Emitter-Sperrspannung	collector-emitter voltage		V_{CES}	600 V
Kollektor-Dauergleichstrom	DC-collector current		I_C	400 A
Periodischer Kollektor Spitzenstrom	repetitive peak collector current	$t_p=1\text{ ms}$	I_{CRM}	800 A
Gesamt-Verlustleistung	total power dissipation	$t_c=25^\circ\text{C}$, Transistor /transistor	P_{tot}	1400 W
Gate-Emitter-Spitzenspannung	gate-emitter peak voltage		V_{GE}	+/- 20 V
Dauergleichstrom	DC forward current		I_F	400 A
Periodischer Spitzenstrom	repetitive peak forw. current	$t_p=1\text{ms}$	I_{FRM}	800 A
Isolations-Prüfspannung	insulating test voltage	RMS, f=50 Hz, t= 1 min.	V_{ISOL}	2,5 kV

Charakteristische Werte / Characteristic values: Transistor

				min.	typ.	max
Kollektor-Emitter Sättigungsspannung	collector-emitter saturation voltage	$i_C=400\text{A}, v_{GE}=15\text{V}, t_{VF}=25^\circ\text{C}$	$V_{CE\text{ sat}}$	-	-	2,7 V
		$i_C=400\text{A}, v_{GE}=15\text{V}, t_{VF}=125^\circ\text{C}$		-	-	2,8 V
Gate-Schwellspannung	gate threshold voltage	$i_C=9\text{mA}, v_{CE}=v_{GE}, t_{VF}=25^\circ\text{C}$	$v_{GE(th)}$	-	5,0	- V
Eingangskapazität	input capacity	$f_C=1\text{MHz}, t_{VF}=25^\circ\text{C}, v_{CE}=25\text{V}, v_{GE}=0$	C_{ies}	-	22	- nF
Kollektor-Emitter Reststrom	collector-emitter cut-off current	$v_{CE}=600\text{V}, v_{GE}=0\text{V}, t_{VF}=25^\circ\text{C}$	i_{CES}	-	8	- mA
		$v_{CE}=600\text{V}, v_{GE}=0\text{V}, t_{VF}=125^\circ\text{C}$		-	80	- mA
Gate-Emitter Reststrom	gate leakage current	$v_{CE}=0\text{V}, v_{GE}=20\text{V}, t_{VF}=25^\circ\text{C}$	i_{GES}	-	-	400 nA
Emitter-Gate Reststrom	gate leakage current	$v_{CE}=0\text{V}, v_{EG}=20\text{V}, t_{VF}=25^\circ\text{C}$	i_{EGS}	-	-	400 nA
Einschaltzeit (induktive Last)	turn-on time (inductive load)	$i_C=400\text{A}, v_{CE}=300\text{V}$	t_{on}			
		$v_L = \pm 15\text{V}, R_G=12\Omega, t_{VF}=25^\circ\text{C}$		-	0,65	- μs
		$v_L = \pm 15\text{V}, R_G=12\Omega, t_{VF}=125^\circ\text{C}$		-	0,65	- μs
Speicherzeit (induktive Last)	storage time (inductive load)	$i_C=400\text{A}, v_{CE}=300\text{V}$	t_s			
		$v_L = \pm 15\text{V}, R_G=27\Omega, t_{VF}=25^\circ\text{C}$		-	1,75	- μs
		$v_L = \pm 15\text{V}, R_G=27\Omega, t_{VF}=125^\circ\text{C}$		-	1,95	- μs
Fallzeit (induktive Last)	fall time (inductive load)	$i_C=400\text{A}, v_{CE}=300\text{V}$	t_f			
		$v_L = \pm 15\text{V}, R_G=27\Omega, t_{VF}=25^\circ\text{C}$		-	0,20	- μs
		$v_L = \pm 15\text{V}, R_G=27\Omega, t_{VF}=125^\circ\text{C}$		-	0,35	- μs

Charakteristische Werte / Characteristic values: Invers-Diode

Durchlaßspannung	forward voltage	$i_F=400\text{A}, v_{GE}=0\text{V}, t_{VF}=25^\circ\text{C}$	V_F	-	-	2,4 V
		$i_F=400\text{A}, v_{GE}=0\text{V}, t_{VF}=125^\circ\text{C}$		-	-	- V
Rückstromspitze	peak reverse recovery current	$i_F=400\text{A}$	I_{RM}			
		$v_{RM}=300\text{V}, v_{EG}=10\text{V}, t_{VF}=25^\circ\text{C}$		-	-	- A
		$v_{RM}=300\text{V}, v_{EG}=10\text{V}, t_{VF}=125^\circ\text{C}$		-	-	- A
Sperrverzögerungsladung	recovered charge	$i_F=400\text{A}$	Q_r			
		$v_{RM}=300\text{V}, v_{EG}=10\text{V}, t_{VF}=25^\circ\text{C}$		-	-	- μAs
		$v_{RM}=300\text{V}, v_{EG}=10\text{V}, t_{VF}=125^\circ\text{C}$		-	-	- μAs

Thermische Eigenschaften / Thermal properties

Innerer Wärmewiderstand	thermal resistance, junction to case	Transistor, DC, pro Modul/per module	R_{thJC}	0,015 $^\circ\text{C/W}$
		Transistor, DC, pro Zweig/per arm		0,090 $^\circ\text{C/W}$
		Diode, DC, pro Modul/per module		0,030 $^\circ\text{C/W}$
		Diode, DC, pro Zweig/per arm		0,180 $^\circ\text{C/W}$
Übergangs-Wärmewiderstand	thermal resistance, case to heatsink	pro Modul / per module	R_{thCK}	0,008 $^\circ\text{C/W}$
		pro Zweig / per arm		0,048 $^\circ\text{C/W}$
Höchstzul. Sperrschichttemperatur	max. junction temperature		$t_{vj\text{ max}}$	150 $^\circ\text{C}$
Betriebstemperatur	operating temperature	Transistor	$t_{c\text{ op}}$	-40...+150 $^\circ\text{C}$
		Diode		-40...+125 $^\circ\text{C}$
Lagertemperatur	storage temperature		t_{stg}	-40...+125 $^\circ\text{C}$

Mechanische Eigenschaften / Mechanical properties

Gehäuse, siehe Anlage	case, see appendix			
Innere Isolation	internal insulation			Al_2O_3
Anzugsdrehmoment f. mech. Befestigung	mounting torque	terminals M6	M1	3 Nm
Anzugsdrehmoment f. elektr. Anschlüsse	terminal connection torque	terminals M6	M2	5...6 Nm
Gewicht	weight		G	ca.1500 g

Mit dieser technischen Information werden Halbleiterbauelemente spezifiziert, jedoch keine Eigenschaften zugesichert. Sie gilt in Verbindung mit den zugehörigen Technischen Erläuterungen. This technical information specifies semiconductor devices but promises no characteristics. It is valid in combination with the belonging technical notes.