

European Power-Semiconductor and Electronics Company

# Marketing Information

## FZ 800 R 33 KF1

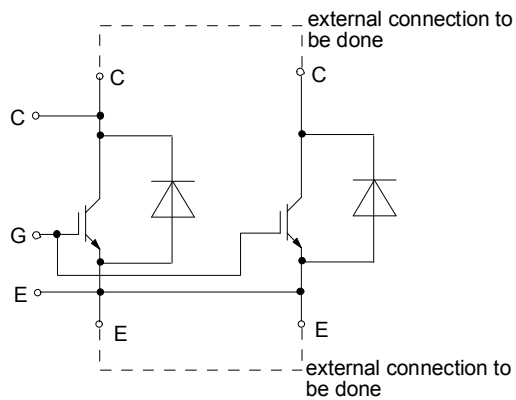
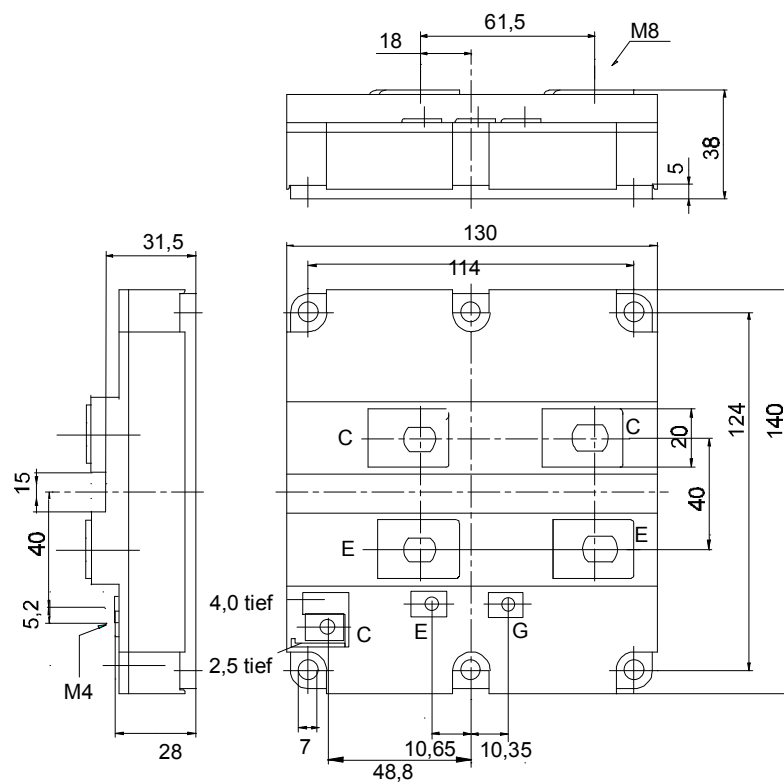

# FZ 800 R 33 KF1

## Höchstzulässige Werte / Maximum rated values

### Elektrische Eigenschaften / Electrical properties

Kollektor-Emitter-Sperrspannung	collector-emitter voltage	$t_{vj} = 25^\circ\text{C}$	$V_{CES}$	3300 V
Kollektor-Dauerstrom	DC-collector current		$I_C$	800 A
Period. Kollektor Spitzenstrom	repetitive peak collector current	$t_p=1\text{ ms}$	$I_{CRM}$	1600 A
Gesamt-Verlustleistung	total power dissipation	$t_c=25^\circ\text{C}$ , Transistor / transistor	$P_{tot}$	8700 W
Gate-Emitter-Spitzenspannung	gate-emitter peak voltage		$V_{GE}$	+/- 20 V
Dauerstrom	DC forward current		$I_F$	800 A
Periodischer Spitzenstrom	repetitive peak forw. current	$t_p=1\text{ms}$	$I_{FRM}$	1600 A
Isolations-Prüfspannung	insulating test voltage	RMS, $f=50\text{ Hz}$ , $t=1\text{ min.}$	$V_{ISOL}$	6 kV

### Charakteristische Werte / Characteristic values: Transistor

				min.	typ.	max
Koll.-Emitter Gleichsperrspannung	coll.-emitter direct off-state voltage	$v_{GE} = -15\text{V}$ , $t_c = -40^\circ\text{C} \dots +125^\circ\text{C}$	$V_{CE(D)}$	-	2100	- V
Koll.-Emitter Sättigungsspannung	coll.-emitter saturation voltage	$i_C = 800\text{ A}$ , $v_{GE} = 15\text{V}$ , $t_{vj} = 25^\circ\text{C}$	$V_{CE\text{ sat}}$	-	3,5	4,2 V
		$i_C = 800\text{ A}$ , $v_{GE} = 15\text{V}$ , $t_{vj} = 125^\circ\text{C}$		-	4,3	- V
Gate-Emitter Schwellenspannung	gate-emitter threshold voltage	$i_C = 80\text{mA}$ , $v_{CE} = v_{GE}$ , $t_{vj} = 25^\circ\text{C}$	$V_{GE(th)}$	4,5	5,5	6,5 V
Eingangskapazität	input capacity	$f_0=1\text{MHz}$ , $t_{vj}=25^\circ\text{C}$	$C_{ies}$	-	100	- nF
		$v_{CE} = 25\text{V}$ , $v_{GE} = 0\text{V}$				
Kollektor-Emitter Reststrom	collector-emitter cut-off current	$v_{CE}=3300\text{V}$ , $v_{GE}=0\text{V}$ , $t_{vj}=25^\circ\text{C}$	$i_{CES}$	-	1	- mA
		$v_{CE}=3300\text{V}$ , $v_{GE}=0\text{V}$ , $t_{vj}=125^\circ\text{C}$		-	40	- mA
Gate-Emitter Reststrom	gate leakage current	$v_{CE}=0\text{V}$ , $v_{GE}=20\text{V}$ , $t_{vj}=25^\circ\text{C}$	$i_{GES}$	-	-	600 nA
Emitter-Gate Reststrom	gate leakage current	$v_{CE}=0\text{V}$ , $v_{GE}=20\text{V}$ , $t_{vj}=25^\circ\text{C}$	$i_{EGS}$	-	-	600 nA
Einschaltzeit (induktive Last)	turn-on time (inductive load)	$i_C=800\text{A}$ , $v_{CE}=1800\text{V}$ , $v_L = \pm 15\text{V}$	$t_{on}$	-	1,1	- $\mu\text{s}$
		$C_{GE}=150\text{nF}$ , $R_G=2,7\Omega$ , $t_{vj}=25^\circ\text{C}$		-	1,1	- $\mu\text{s}$
		$C_{GE}=150\text{nF}$ , $R_G=2,7\Omega$ , $t_{vj}=125^\circ\text{C}$		-	1,1	- $\mu\text{s}$
Speicherzeit (induktive Last)	storage time (inductive load)	$i_C=800\text{A}$ , $v_{CE}=1800\text{V}$ , $v_L = \pm 15\text{V}$	$t_s$	-	3,4	- $\mu\text{s}$
		$C_{GE}=150\text{nF}$ , $R_G=5,1\Omega$ , $t_{vj}=25^\circ\text{C}$		-	3,8	- $\mu\text{s}$
		$C_{GE}=150\text{nF}$ , $R_G=5,1\Omega$ , $t_{vj}=125^\circ\text{C}$		-	3,8	- $\mu\text{s}$
Fallzeit (induktive Last)	fall time (inductive load)	$i_C=800\text{A}$ , $v_{CE}=1800\text{V}$ , $v_L = \pm 15\text{V}$	$t_f$	-	0,2	- $\mu\text{s}$
		$C_{GE}=150\text{nF}$ , $R_G=5,1\Omega$ , $t_{vj}=25^\circ\text{C}$		-	0,2	- $\mu\text{s}$
		$C_{GE}=150\text{nF}$ , $R_G=5,1\Omega$ , $t_{vj}=125^\circ\text{C}$		-	0,2	- $\mu\text{s}$

### Charakteristische Werte / Characteristic values: Transistor

Einschaltverlustleistung pro Puls	turn-on energy loss per pulse	$i_C=800\text{A}$ , $v_{CE}=1800\text{V}$ , $v_L = \pm 15\text{V}$	$E_{on}$	-	2,2	- Ws
		$C_{GE}=150\text{nF}$ , $R_G=2,7\Omega$ , $t_{vj}=125^\circ\text{C}$		-	2,2	- Ws
		$L_S = 70\text{nH}$		-	1,3	- Ws
Abschaltverlustenergie pro Puls	turn-off energy loss per pulse	$i_C=800\text{A}$ , $v_{CE}=1800\text{V}$ , $v_L = \pm 15\text{V}$	$E_{off}$	-	1,3	- Ws
		$C_{GE}=150\text{nF}$ , $R_G=5,1\Omega$ , $t_{vj}=125^\circ\text{C}$		-	1,3	- Ws
		$L_S = 70\text{nH}$		-	1,3	- Ws
Inversodiode / Inverse diode				min.	typ.	max.
Durchlaßspannung	forward voltage	$i_F=800\text{A}$ , $v_{GE}=0\text{ V}$ , $t_{vj} = 25^\circ\text{C}$	$v_F$	-	2,7	3,5 V
		$i_F=800\text{A}$ , $v_{GE}=0\text{ V}$ , $t_{vj} = 125^\circ\text{C}$		-	2,8	- V
Rückstromspitze	peak reverse recovery current	$i_F=800\text{A}$ , $-di_F/dt = 3200\text{ A}/\mu\text{s}$	$I_{RM}$	-	630	- A
		$v_{RM}=1800\text{V}$ , $v_{EG}=10\text{V}$ , $t_{vj}=25^\circ\text{C}$		-	800	- A
		$v_{RM}=1800\text{V}$ , $v_{EG}=10\text{V}$ , $t_{vj}=125^\circ\text{C}$		-	800	- A
Sperrverzögerungsladung	recovered charge	$i_F=800\text{A}$ , $-di_F/dt = 3200\text{ A}/\mu\text{s}$	$Q_r$	-	500	- $\mu\text{As}$
		$v_{RM}=1800\text{V}$ , $v_{EG}=10\text{V}$ , $t_{vj}=25^\circ\text{C}$		-	600	- $\mu\text{As}$
		$v_{RM}=1800\text{V}$ , $v_{EG}=10\text{V}$ , $t_{vj}=125^\circ\text{C}$		-	600	- $\mu\text{As}$

### Thermische Eigenschaften / Thermal properties

Innerer Wärmewiderstand	thermal resist., junction to case	Transistor / transistor, DC	$R_{thJC}$		0,0143 $^\circ\text{C}/\text{W}$
		Diode, diode, DC			0,0270 $^\circ\text{C}/\text{W}$
Übergangs-Wärmewiderstand	thermal resist., case to heatsink	pro Modul / per Module	$R_{thCK}$		0,008 $^\circ\text{C}/\text{W}$
Höchstzul. Sperrschichttemp.	max. junction temperature		$t_{vj\text{ max}}$		150 $^\circ\text{C}$
Betriebstemperatur	operating temperature		$t_{c\text{ op}}$		-40...+125 $^\circ\text{C}$
Lagertemperatur	storage temperature		$t_{stg}$		-40...+125 $^\circ\text{C}$

### Mechanische Eigenschaften / Mechanical properties

Gehäuse	case				Seite 1
Innere Isolation	internal insulation				ALN
Anzugsdrehm. f. mech. Befest.	mounting torque	terminals M6/tolerance $\pm 10\%$	M1		5 Nm
Anzugsdrehm. f. elektr. Anschl.	terminal connection torque	terminals M4/tolerance +5/-10%	M2		2 Nm
		terminals M8			8...10 Nm
Gewicht	weight		G		1500 g

Mit dieser technischen Information werden Halbleiterbauelemente spezifiziert, jedoch keine Eigenschaften zugesichert. Sie gilt in Verbindung mit dem zugehörigen Technischen Erläuterungen. This technical information specifies semiconductor devices but promises no characteristics. It is valid in combination with the belonging technical notes.

Bedingungen für den Kurzschlußschutz / Conditions for short-circuit protection	Unabhängig davon gilt bei abweichenden Bedingungen with regard to other conditions
$t_{ig} = 10\ \mu\text{s}$	$V_{CC} = 2500\text{ V}$
$v_L = \pm 15\text{ V}$ ; $C_{GE} = 150\text{ nF}$	$V_{CEM} = 3300\text{ V}$
$R_{GR} = 2,7\Omega$ ; $R_{GR} = 5,1\Omega$	$i_{CMK1} = 2800\text{ A}$
$t_{vj} = 125^\circ\text{C}$	$i_{CMK2} = 2400\text{ A}$

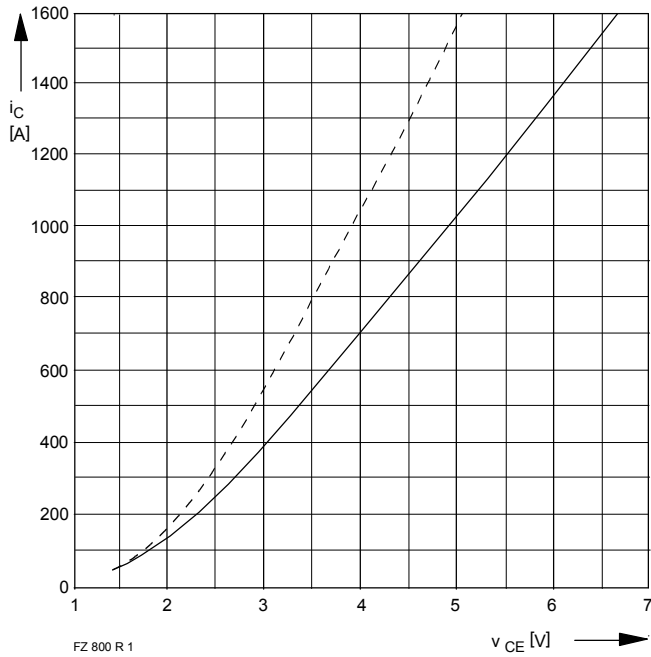

FZ 800 R 1

Bild/Fig. 1  
 Kollektor-Emitter-Spannung im Sättigungsbereich (typisch)  
 Collector-emitter-voltage in saturation region (typical)  
 $V_{GE} = 15 \text{ V}$   
 .....  $t_{vj} = 125 \text{ }^\circ\text{C}$   
 —  $t_{vj} = 25 \text{ }^\circ\text{C}$

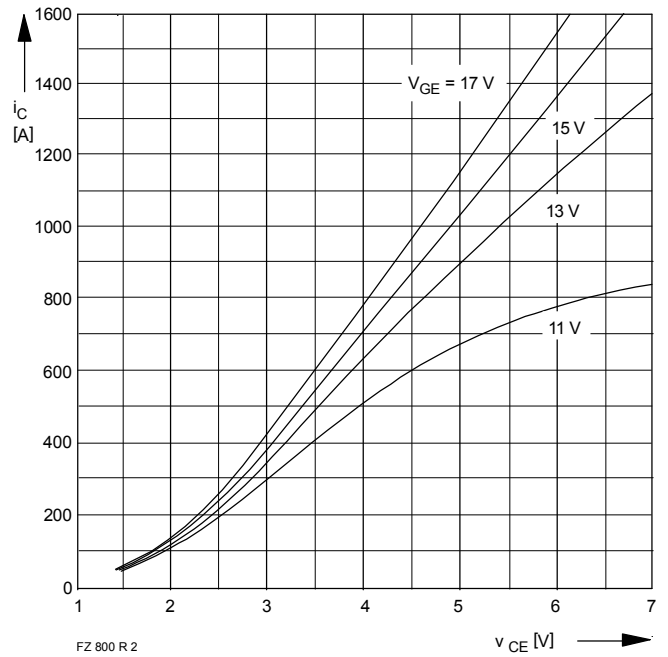

FZ 800 R 2

Bild/Fig. 2  
 Kollektor-Emitter-Spannung im Sättigungsbereich (typisch)  
 Collector-emitter-voltage in saturation region (typical)  
 $t_{vj} = 125 \text{ }^\circ\text{C}$

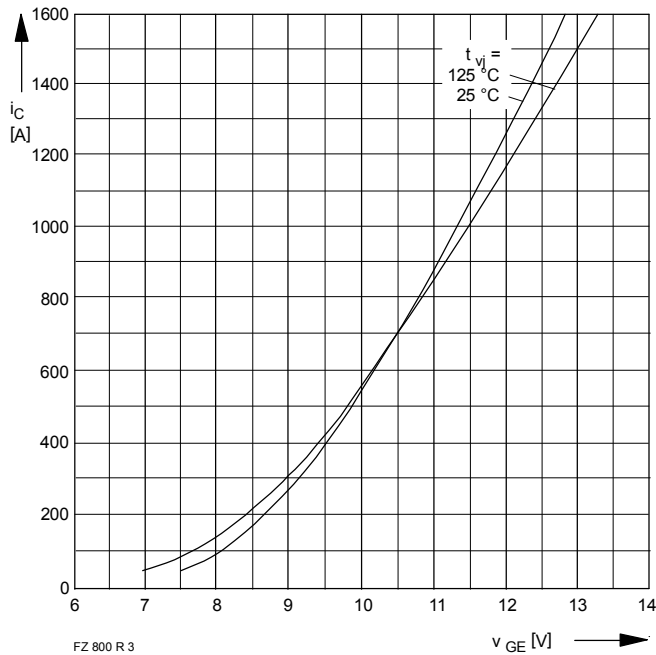

FZ 800 R 3

Bild/Fig. 3  
 Übertragungscharakteristik (typisch)  
 Transfer characteristic (typical)  
 $V_{CE} = 20 \text{ V}$

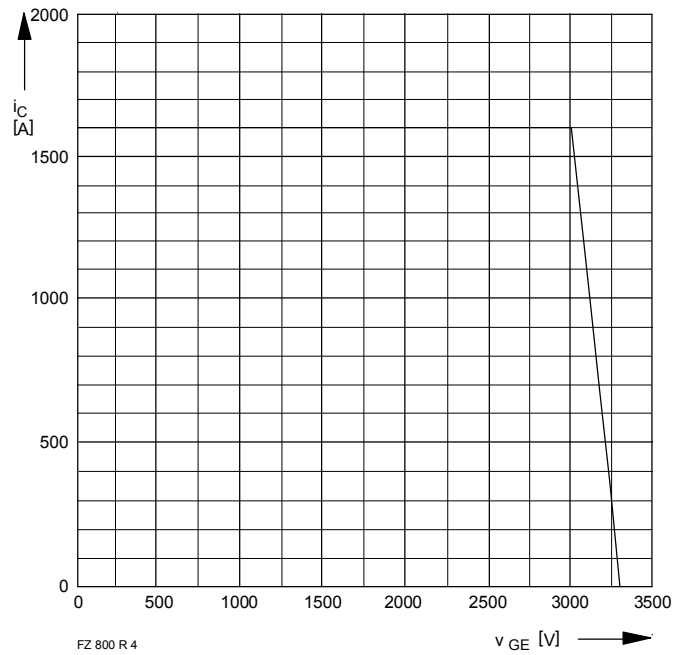

FZ 800 R 4

Bild/Fig. 4  
 Rückwärts-Arbeitsbereich  
 Reverse biased safe operating area  
 $t_{vj} = 125 \text{ }^\circ\text{C}$ ,  $v_{LF} = v_{LR} = 15 \text{ V}$ ,  $R_{GF} = 2,7 \text{ } \Omega$ ,  $R_{GR} = 5,1 \text{ } \Omega$   
 $C_{GE} = 150 \text{ nF}$ ,  $dv_{CE}/dt \leq 3000 \text{ V}/\mu\text{s}$

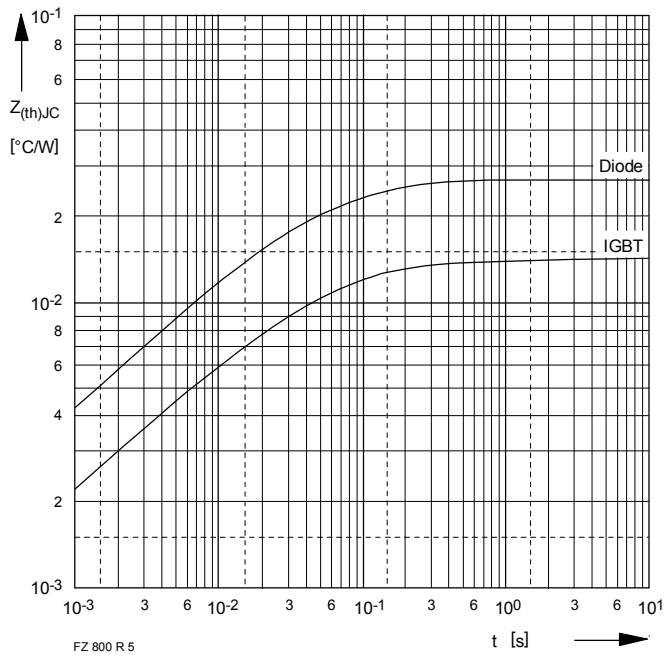

FZ 800 R 5  
 Bild/Fig. 5  
 Transienter innerer Wärmewiderstand (DC)  
 Transient thermal impedance (DC)

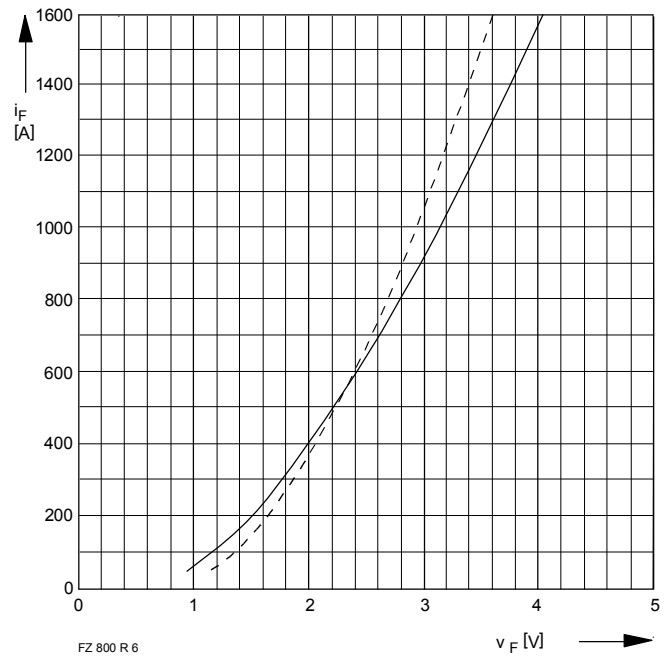

FZ 800 R 6  
 Bild/Fig. 6  
 Durchlaßkennlinie der Inversdiode (typisch)  
 Forward characteristic of the inverse diode (typical)  
 .....  $t_{vj} = 25^{\circ}C$   
 —  $t_{vj} = 125^{\circ}C$