

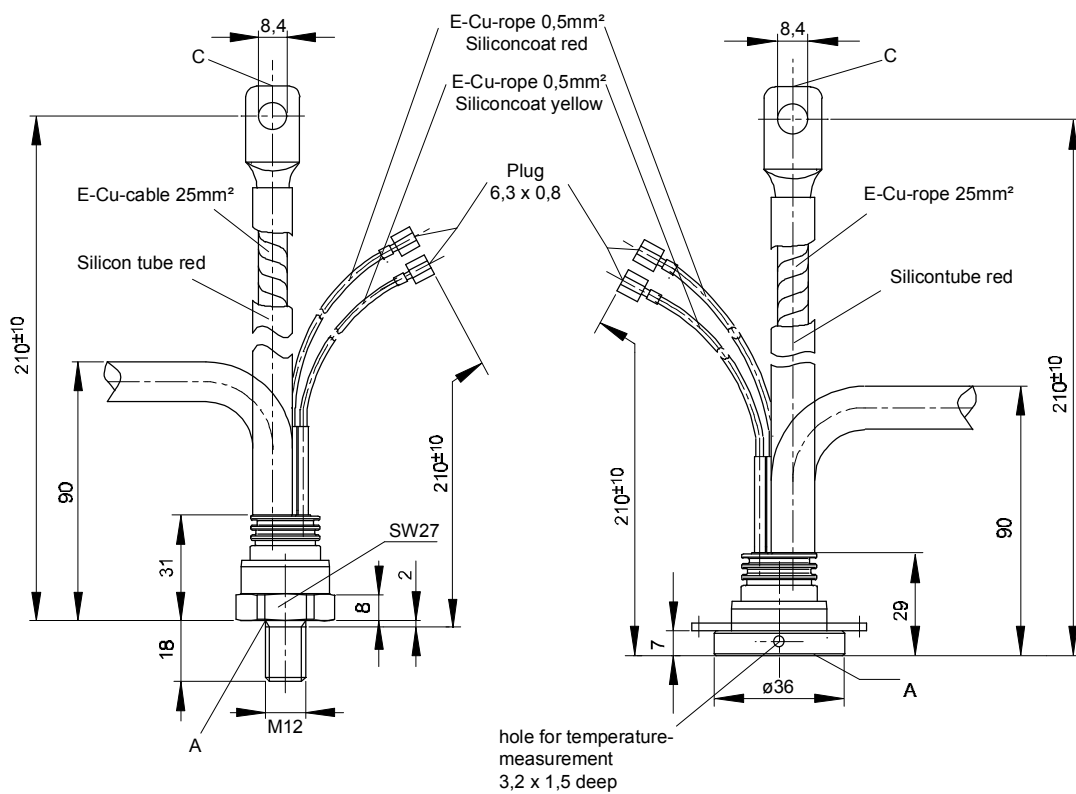

European Power-Semiconductor and Electronics Company

Marketing Information

T 130 N



T 130 N

Elektrische Eigenschaften

Höchstzulässige Werte

Periodische Vorwärts- und Rückwärts-Spitzensperrspannung

Electrical properties

Maximum rated values

repetitive peak forward off-state and reverse voltages

Vorwärts-Stoßspitzensperrspannung

non-repetitive peak forward off-state voltage

Rückwärts-Stoßspitzensperrspannung

non-repetitive peak reverse voltage

Durchlaßstrom-Grenzeffektivwert

RMS on-state current

Dauergrenzstrom

average on-state current

Stoßstrom-Grenzwert

surge current

Grenzlastintegral

$I^2 t$ -value

Kritische Stromsteilheit

critical rate of rise of on-state current

Kritische Spannungssteilheit

critical rate of rise of off-state voltage

Charakteristische Werte

Durchlaßspannung

on-state voltage

Schleusenspannung

threshold voltage

Ersatzwiderstand

slope resistance

Zündstrom

gate trigger current

Zündspannung

gate trigger voltage

Nicht zündender Steuerstrom

gate non-trigger current

Nicht zündende Steuerspannung

gate non-trigger voltage

Haltestrom

holding current

Einraststrom

latching current

Vorwärts- und Rückwärts-Sperrstrom

forward off-state and reverse currents

Zündverzug

gate controlled delay time

Freiwerdezeit

circuit commutated turn-off time

Thermische Eigenschaften

Innerer Wärmewiderstand

Thermal properties

thermal resistance, junction to case

Höchstzul. Sperrschichttemperatur

max. junction temperature

Betriebstemperatur

operating temperature

Lagertemperatur

storage temperature

Mechanische Eigenschaften

Si-Elemente mit Druckkontakt

Mechanical properties

Si-pellet with pressure contact

Anzugsdrehmoment

tightening torque

Anpreßkraft

clamping force

Gewicht, Bauform E

weight, case design E

Kriechstrecke

creepage distance

Feuchteklasse

humidity classification

Schwingfestigkeit

vibration resistance

Maßbild, anliegend

outline, attached

$t_{vj} = -40^{\circ}\text{C} \dots t_{vj \max}$	$V_{\text{DRM}}, V_{\text{RRM}}$	600 800 1000 1200 1400 1600 1800	V
$t_{vj} = -40^{\circ}\text{C} \dots t_{vj \max}$	$V_{\text{DSM}} = V_{\text{DRM}}$	600 800 1000 1200 1400 1600 1800	V
$t_{vj} = +25^{\circ}\text{C} \dots t_{vj \max}$	$V_{\text{RSM}} = V_{\text{RRM}}$	700 900 1100 1300 1500 1700 1900	V
$t_c = 85^{\circ}\text{C}$	I_{TRMSM}	300	A
$t_c = 56^{\circ}\text{C}$	I_{TAVM}	130	A
$t_{vj} = 25^{\circ}\text{C}, t_p = 10 \text{ ms}$	I_{TSM}	3500	A
$t_{vj} = t_{vj \max}, t_p = 10 \text{ ms}$		3000	A
$t_{vj} = 25^{\circ}\text{C}, t_p = 10 \text{ ms}$	$I^2 t$	61000	A^2s
$t_{vj} = t_{vj \max}, t_p = 10 \text{ ms}$		45000	A^2s
$V_D \leq 67\%, V_{\text{DRM}}, f = 50 \text{ Hz}$	$(di_T/dt)_{cr}$	150	$\text{A}/\mu\text{s}$
$V_L = 10 \text{ V}, i_{\text{GM}} = 0,75 \text{ A}, di_G/dt = 0,75 \text{ A}/\mu\text{s}$			
$t_{vj} = t_{vj \max}, V_D = 67\% V_{\text{DRM}}$	$(dv/dt)_{cr}$	1000	$\text{V}/\mu\text{s}$

$t_{vj} = t_{vj \max}, i_T = 600 \text{ A}$	V_T	max. 1,96	V
$t_{vj} = t_{vj \max}$	$V_{T(\text{TO})}$	1,08	V
$t_{vj} = t_{vj \max}$	r_T	1,53	$\text{m}\Omega$
$t_{vj} = 25^{\circ}\text{C}, V_D = 6 \text{ V}$	I_{GT}	max. 150	mA
$t_{vj} = 25^{\circ}\text{C}, V_D = 6 \text{ V}$	V_{GT}	max. 1,4	V
$t_{vj} = t_{vj \max}, V_D = 6 \text{ V}$	I_{GD}	max. 5	mA
$t_{vj} = t_{vj \max}, V_D = 0,5 V_{\text{DRM}}$	V_{GD}	max. 0,2	V
$t_{vj} = 25^{\circ}\text{C}, V_D = 6 \text{ V}, R_A = 5 \Omega$	I_H	max. 200	mA
$t_{vj} = 25^{\circ}\text{C}, V_D = 6 \text{ V}, R_{\text{GK}} \geq 10 \Omega$	I_L	max. 620	mA
$i_{\text{GM}} = 0,75 \text{ A}, di_G/dt = 0,75 \text{ A}/\mu\text{s}, t_g = 20 \mu\text{s}$			
$t_{vj} = t_{vj \max}, V_D = V_{\text{DRM}}, v_R = V_{\text{RRM}}$	i_D, i_R	max. 30	mA
$t_{vj} = 25^{\circ}\text{C}, i_{\text{GM}} = 0,75 \text{ A}, di_G/dt = 0,75 \text{ A}/\mu\text{s}$	t_{gd}	max. 4,5	μs
siehe Techn.Erl./see Techn. Inf.	t_q	typ. 180	μs

$\Theta = 180^{\circ} \text{ el, sin}$	R_{thJC}	max. 0,2	$^{\circ}\text{C}/\text{W}$
DC		max. 0,19	$^{\circ}\text{C}/\text{W}$
	$t_{vj \max}$	125	$^{\circ}\text{C}$
	$t_{c \text{ op}}$	-40...+125	$^{\circ}\text{C}$
	t_{stg}	-40...+150	$^{\circ}\text{C}$

Gehäuseform/case design B	M	20	Nm
Gehäuseform/case design E	F	3,5	kN
	G	typ. 190	g
		8	mm
DIN 40040			C
$f = 50 \text{ Hz}$		50	m/s^2
DIN 41 894-222A4/DIN 41892-204B3			



Bild / Fig. 1
Durchlaßkennlinien / On-state characteristics $i_T = f(v_T)$
a - Typische Kennlinien / typical characteristics
b - Grenzkennlinien / limiting characteristics



Bild / Fig. 2
Durchlaßverlustleistung / On-state power loss $P_{TAV} = f(I_{TAV})$
Parameter: Stromflußwinkel / Current conduction angle θ

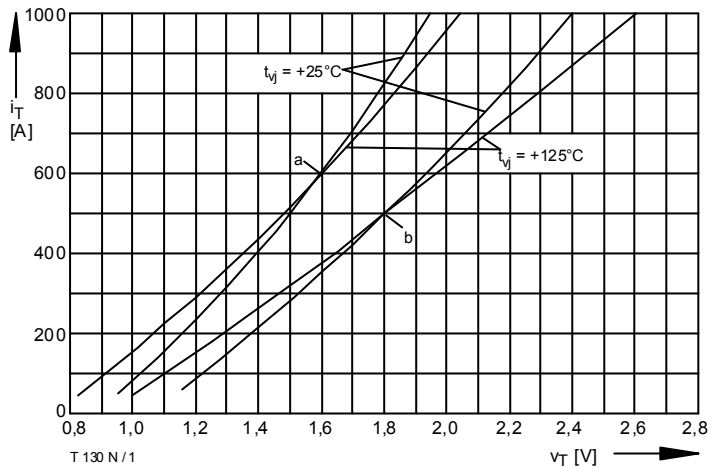

Bild / Fig. 3
Höchstzulässige Gehäusetemperatur / Max. allowable case temperature
 $t_C = f(I_{TAVM})$
Parameter: Stromflußwinkel / Current conduction angle θ

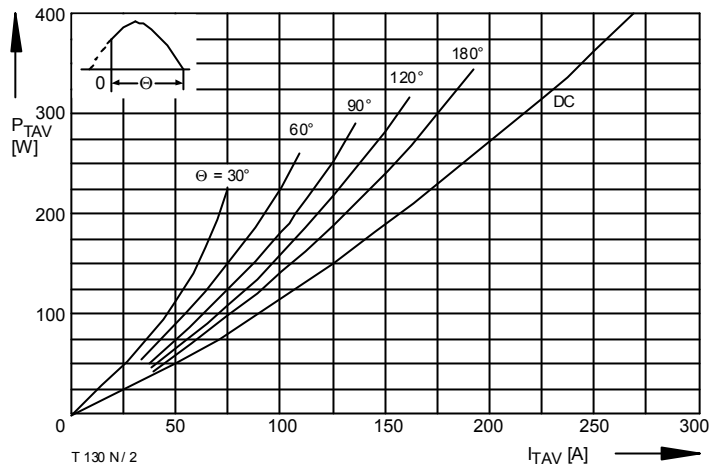

Bild / Fig. 4
Höchstzulässige Kühlmitteltemperatur / Max. allowable cooling medium temperature $t_A = f(I_{TAVM})$
Luftsebstkühlung / Natural air-cooling
Kühlkörper / Heatsink: K1.1-M12-A
Parameter: Stromflußwinkel / Current conduction angle θ

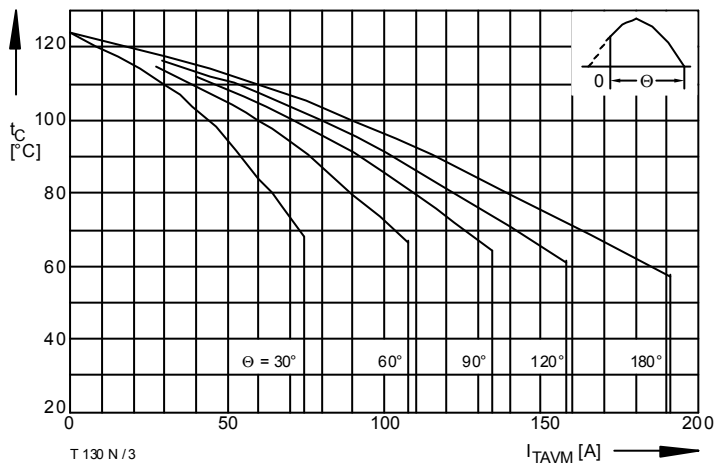

Bild / Fig. 5
Höchstzulässige Kühlmitteltemperatur / Max. allowable cooling medium temperature $t_A = f(I_{TAVM})$
Verstärkte Luftkühlung / forced air cooling
Kühlkörper / Heatsink: K1.1-M12-A, $V_L = 30 \text{ l/s}$
Parameter: Stromflußwinkel / Current conduction angle θ

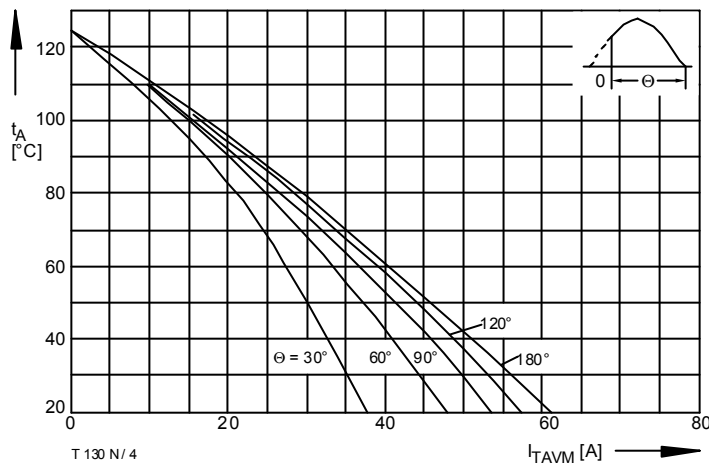

Bild / Fig. 6
 Höchstzulässige Kühlmitteltemperatur / Max. allowable cooling medium temperature $t_A = f(I_{TAVM})$
 Luftselbstkühlung / Natural air-cooling
 Kühlkörper / Heatsink: K0.55-M12-A
 Parameter: Stromflußwinkel / Current conduction angle θ

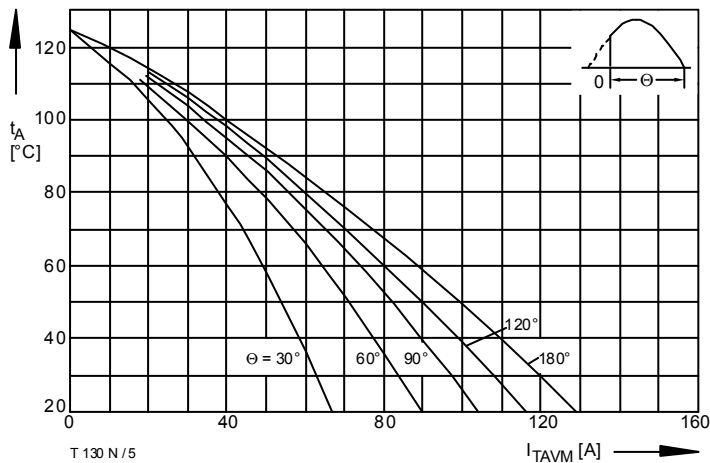

Bild / Fig. 7
 Höchstzulässige Kühlmitteltemperatur / Max. allowable cooling medium temperature $t_A = f(I_{TAVM})$
 Verstärkte Luftkühlung / forced air cooling
 Kühlkörper / Heatsink: K0.55-M12-A, $V_L = 50$ l/s
 Parameter: Stromflußwinkel / Current conduction angle θ

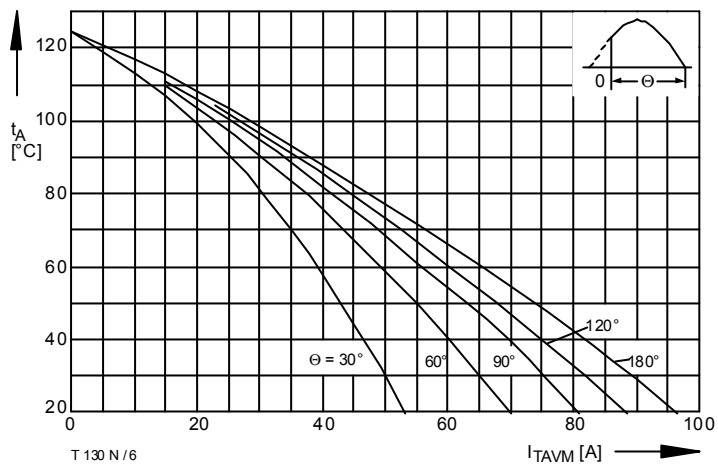

Bild / Fig. 8
 Durchlaßverlustleistung / On-state power loss $P_{TAV} = f(I_{TAV})$
 Parameter: Stromflußwinkel / Current conduction angle θ

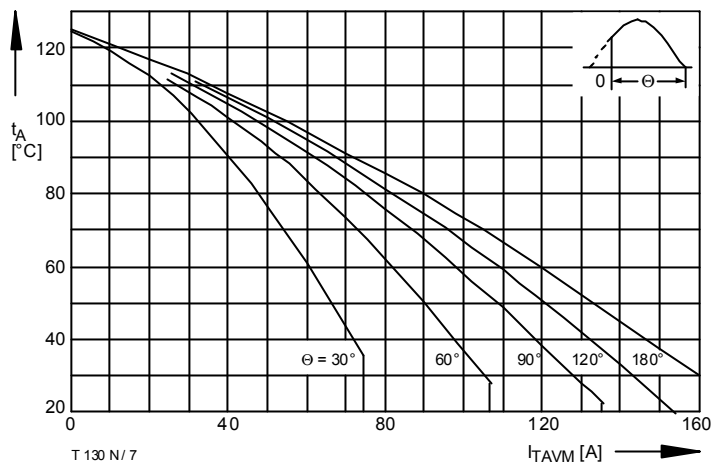

Bild / Fig. 9
 Höchstzulässige Gehäusetemperatur / Max. allowable case temperature $t_C = f(I_{TAVM})$
 Parameter: Stromflußwinkel / Current conduction angle θ

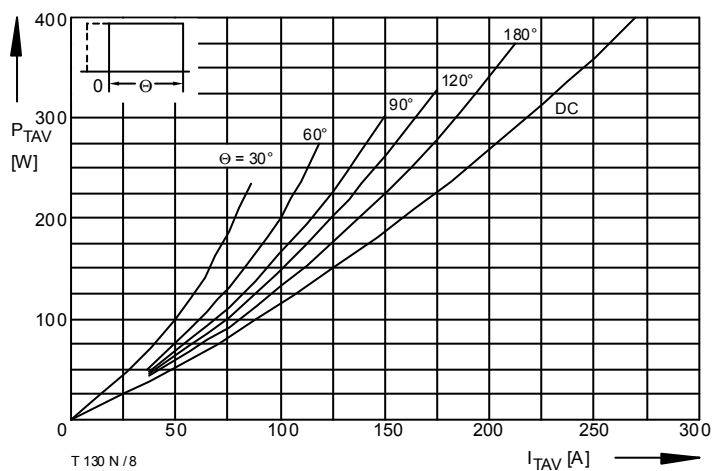

Bild / Fig. 10
 Höchstzulässige Kühlmitteltemperatur / Max. allowable cooling medium temperature $t_A = f(I_{TAVM})$
 Luftselbstkühlung / Natural air-cooling
 Kühlkörper / Heatsink: K1.1-M12-A
 Parameter: Stromflußwinkel / Current conduction angle θ

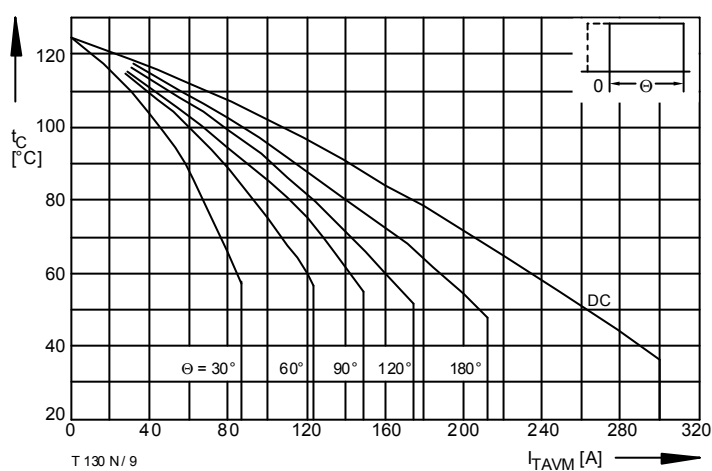

Bild / Fig. 11
 Höchstzulässige Kühlmitteltemperatur / Max. allowable cooling medium temperature $t_A = f(I_{TAVM})$
 Verstärkte Luftkühlung / forced air cooling
 Kühlkörper / Heatsink: K1.1-M12-A, $V_L = 30$ l/s
 Parameter: Stromflußwinkel / Current conduction angle θ

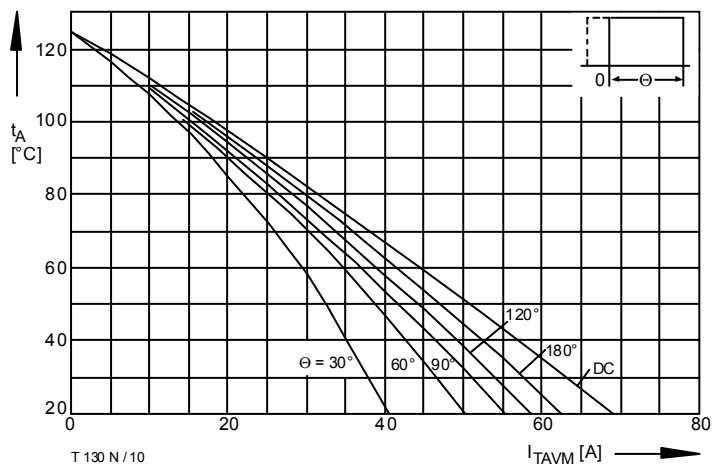

Bild / Fig. 12
 Höchzulässige Kühlmitteltemperatur / Max. allowable cooling medium temperature $t_A = f(I_{TAVM})$
 Luftselbstkühlung / Natural air-cooling
 Kühlkörper / Heatsink: K0.55-M12-A
 Parameter: Stromflußwinkel / Current conduction angle θ

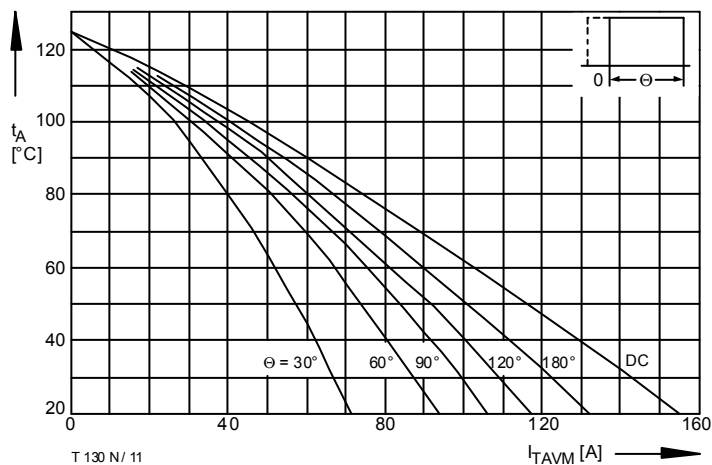

Bild / Fig. 13
 Höchzulässige Kühlmitteltemperatur / Max. allowable cooling medium temperature $t_A = f(I_{TAVM})$
 Verstärkte Luftkühlung / Forced air-cooling,
 Kühlkörper / Heatsink: K0.55-M12-A, $V_L = 50$ l/s
 Parameter: Stromflußwinkel / Current conduction angle θ

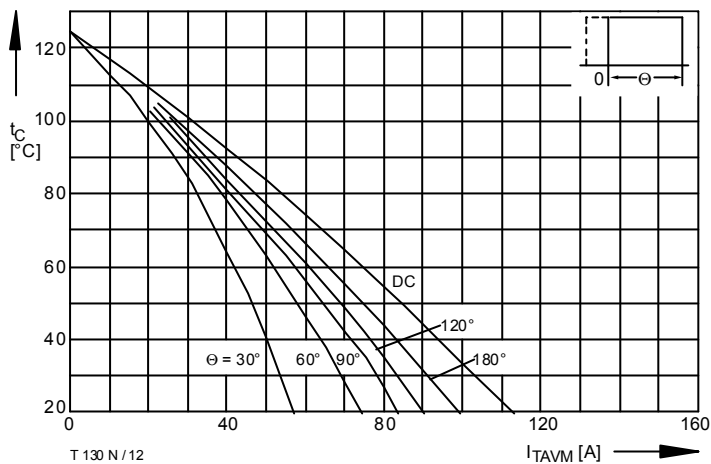

Bild / Fig. 14
 Überstrom / Overload on-state current $I_{T(OV)} = f(t)$
 Luftselbstkühlung / Natural air-cooling, $t_A = 45$ °C
 Kühlkörper / Heatsink: K0.11-M12-A
 Parameter: Vorlaststrom / Pre-load current $I_{TAV(vor)}$

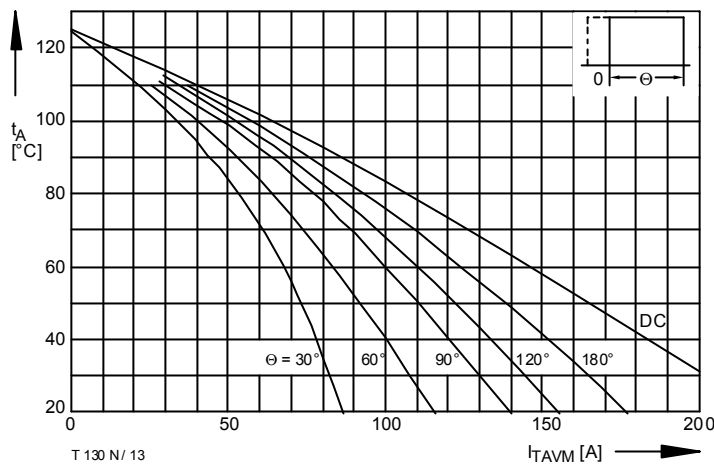

Bild / Fig. 15
 Überstrom / Overload on-state current $I_{T(OV)} = f(t)$
 Verstärkte Luftkühlung / Forced air-cooling, $t_A = 35$ °C
 Kühlkörper / Heatsink: K0.11-M12-A, $V_L = 30$ l/s
 Parameter: Vorlaststrom / Pre-load current $I_{TAV(vor)}$

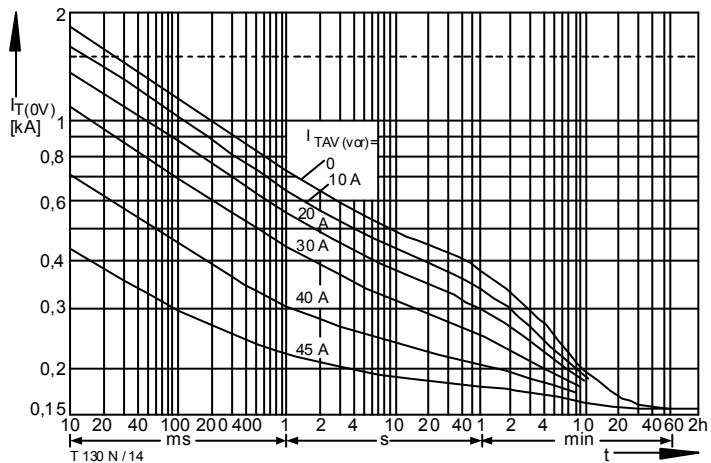

Bild / Fig. 16
 Überstrom / Overload on-state current $I_{T(OV)} = f(t)$
 Luftselbstkühlung / Natural air-cooling, $t_A = 45$ °C
 Kühlkörper / Heatsink: K0.55-M12-A
 Parameter: Vorlaststrom / Pre-load current $I_{TAV(vor)}$

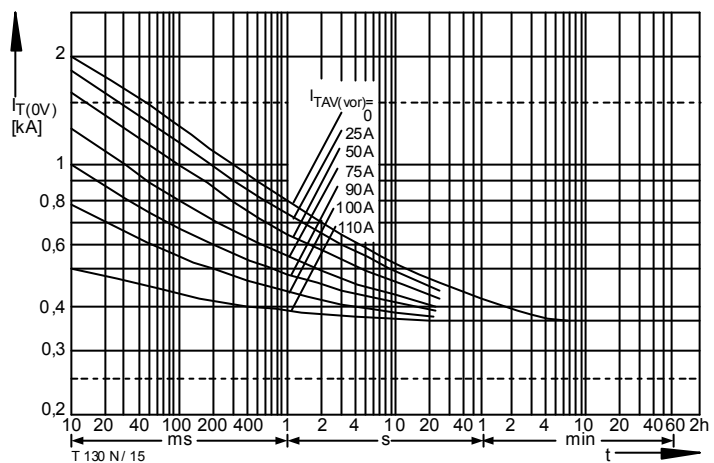

Bild / Fig. 17
 Überstrom / Overload on-state current $I_{T(OV)} = f(t)$
 Verstärkte Luftkühlung / Forced air-cooling, $t_A = 35$ °C
 Kühlkörper / Heatsink: K0.55-M12-A, $V_L = 50$ l/s
 Parameter: Vorlaststrom / Pre-load current $I_{TAV(vor)}$

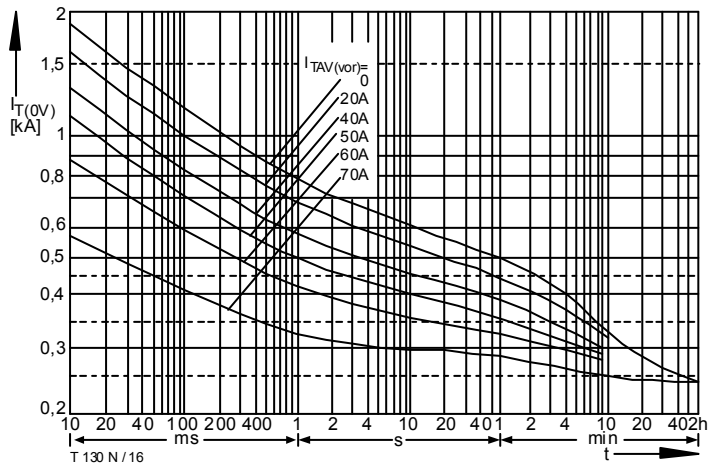

Bild / Fig. 18
 Höchstzulässiger Durchlaßstrom bei Aussetzbetrieb / Max. allowable on-state current at intermittent operation $I_{TINT} = f(ED)$
 Luftselbstkühlung / Natural air-cooling, $t_A = 45^\circ\text{C}$
 Kühlkörper / Heatsink: K1.1-M12-A
 Parameter: Spieldauer / Cycle duration SD
 Vorlaststrom / Pre-load current $I_{TAV(vor)}$

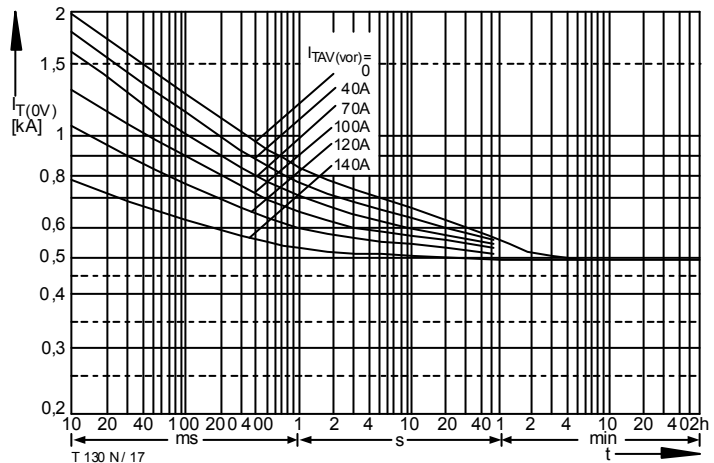

Bild / Fig. 19
 Höchstzulässiger Durchlaßstrom bei Aussetzbetrieb / Max. allowable on-state current at intermittent operation $I_{TINT} = f(ED)$
 Verstärkte Luftkühlung / Forced air-cooling, $t_A = 35^\circ\text{C}$, $V_L = 30 \text{ l/s}$
 Kühlkörper / Heatsink: K1.1-M12-A
 Parameter: Spieldauer / Cycle duration SD
 Vorlaststrom / Pre-load current $I_{TAV(vor)}$

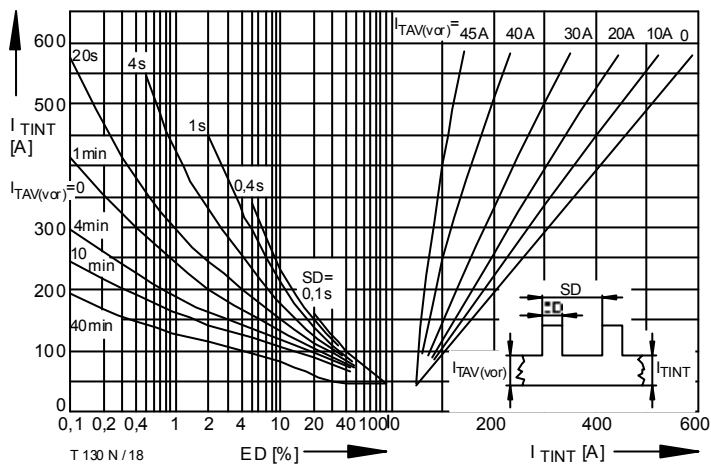

Bild / Fig. 20
 Höchstzulässiger Durchlaßstrom bei Aussetzbetrieb / Max. allowable on-state current at intermittent operation $I_{TINT} = f(ED)$
 Luftselbstkühlung / Natural air-cooling, $t_A = 45^\circ\text{C}$
 Kühlkörper / Heatsink: K0.55-FB54-A
 Parameter: Spieldauer / Cycle duration SD
 Vorlaststrom / Pre-load current $I_{TAV(vor)}$

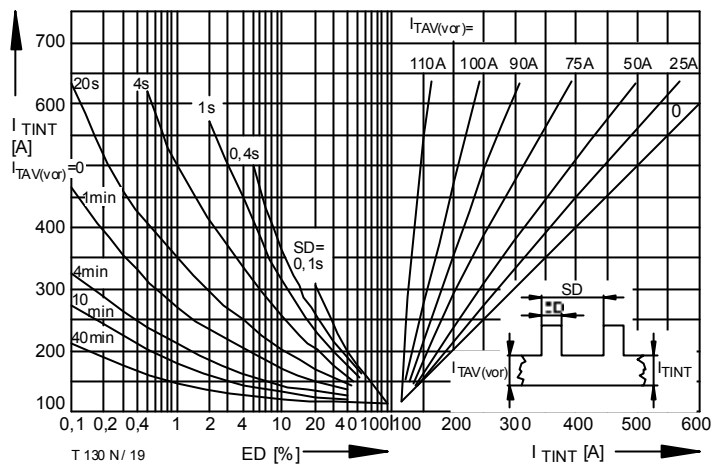

Bild / Fig. 21
 Höchstzulässiger Durchlaßstrom bei Aussetzbetrieb / Max. allowable on-state current at intermittent operation $I_{TINT} = f(ED)$
 Verstärkte Luftkühlung / Forced air-cooling, $t_A = 35^\circ\text{C}$, $V_L = 50 \text{ l/s}$
 Kühlkörper / Heatsink: K0.55-M12-A
 Parameter: Spieldauer / Cycle duration SD
 Vorlaststrom / Pre-load current $I_{TAV(vor)}$

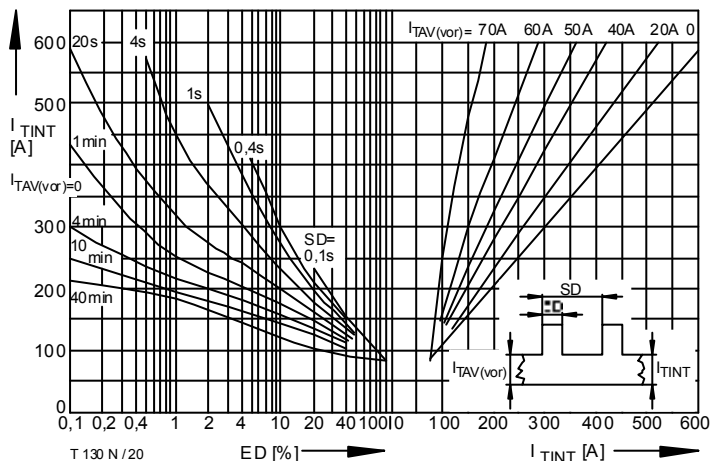

Bild / Fig. 22
 Grenzstrom / Max. overload on-state current $I_{T(OV)M} = f(t)$, $v_{RM} = 0,8 V_{RRM}$
 ----- Luftselbstkühlung / Natural air-cooling, $t_A = 45^\circ\text{C}$
 ----- Verstärkte Luftkühlung / Forced air-cooling, $t_A = 35^\circ\text{C}$, $V_L = 30 \text{ l/s}$
 Kühlkörper / Heatsink: K1.1-M12-A
 Belastung aus / Surge current occurs:
 a - Leerlauf / No-load conditions
 b - Betrieb mit Dauerrenzstrom / During operation at max. average on-state current I_{TAVM}

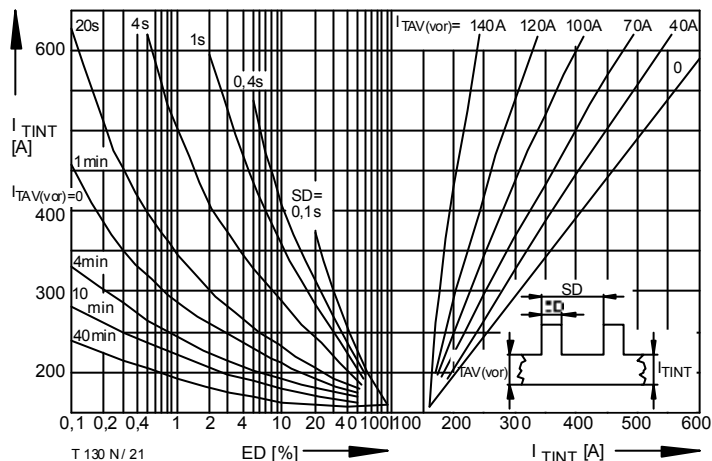

Bild / Fig. 23
 Grenzstrom / Max. overload on-state current $I_{T(OV)M} = f(t)$, $v_{RM} = 0,8 V_{RRM}$
 ----- Luftselbstkühlung / Natural air-cooling, $t_A = 45^\circ\text{C}$
 ----- Verstärkte Luftkühlung / Forced air-cooling, $t_A = 35^\circ\text{C}$, $V_L = 50 \text{ l/s}$
 Kühlkörper / Heatsink: K0.55-FB54-A
 Belastung aus / Surge current occurs:
 a - Leerlauf / No-load conditions
 b - Betrieb mit Dauerrenzstrom / During operation at max. average on-state current I_{TAVM}

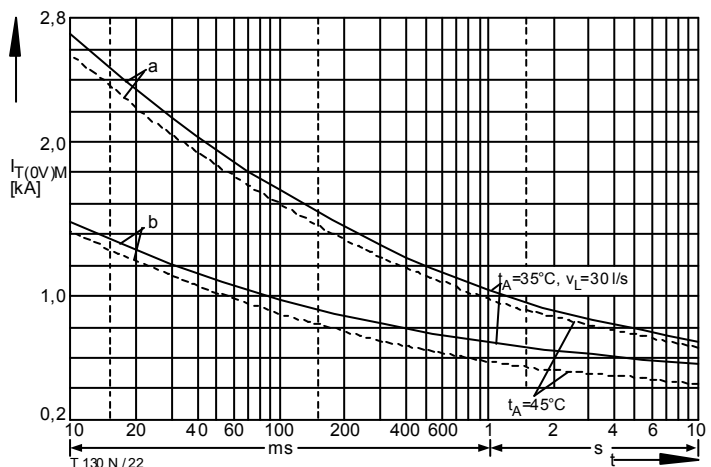

Bild / Fig. 24

Steuercharakteristik mit Zündbereichen / Gate characteristic with triggering areas $v_G = f(i_G)$, $V_D = 6\text{ V}$

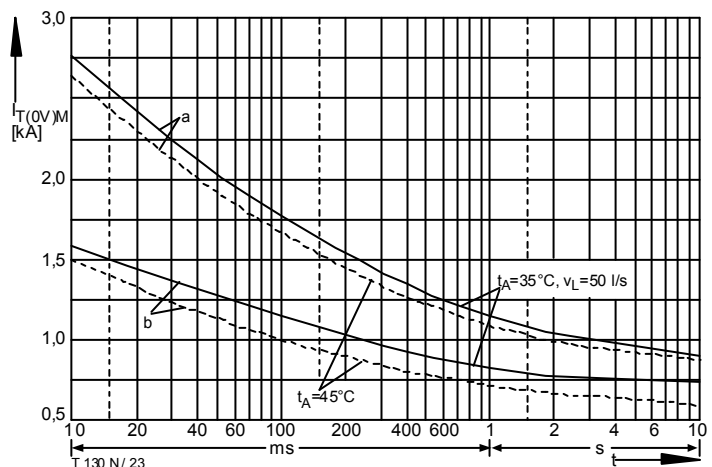
Parameter:

Steuerimpulsdauer / trigger puls duration t_g [ms]	a	b	c	d
	10	1	0,5	0,1

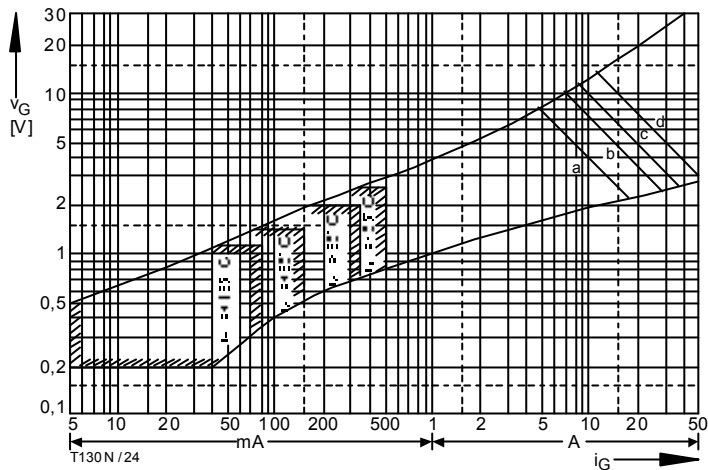
Höchstzulässige Spitzensteuerleistung /

Max. rated peak gate power dissipation [W]	40	80	100	150
--	----	----	-----	-----



Bild / Fig. 25

Zündverzögerung / Gate controlled delay time $t_{gd} = f(i_{GM})$

$t_{vj} = 25\text{ °C}$, $di_G/dt = i_{GM}/1\mu\text{s}$

a - Maximaler Verlauf / Limiting characteristic

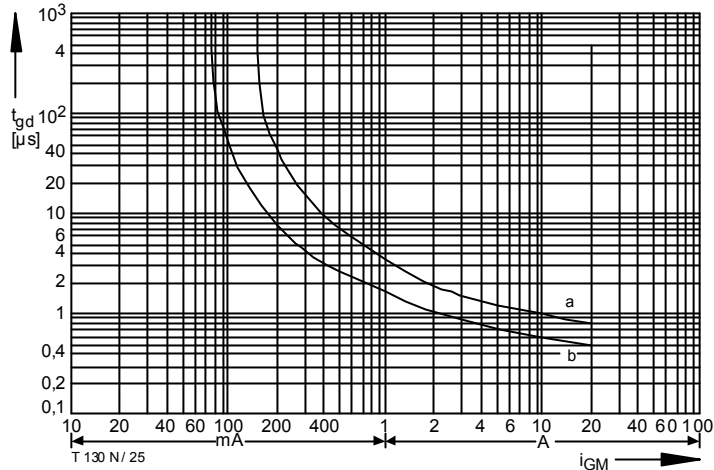
b - Typischer Verlauf / Typical characteristic



Bild / Fig. 26

Sperrverzögerungsladung / Recovered charge $Q_r = f(di/dt)$

$t_{vj} = t_{vj\text{ max}}$, $V_R = 0,5 V_{RRM}$, $V_{RM} = 0,8 V_{RRM}$

Parameter: Durchlaßstrom / On-state current i_{TM}

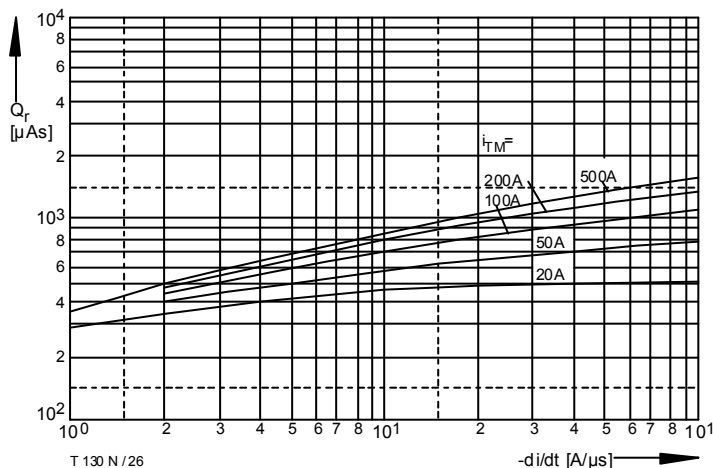

Bild / Fig. 27

Transienter innerer Wärmewiderstand / Transient thermal impedance $Z_{thJC} = f(t)$

Parameter: Stromflußwinkel / current conduction angle θ

Analytische Elemente des transienten Wärmewiderstandes Z_{thJC} pro Zweig für DC
Analytical elements of transient thermal impedance Z_{thJC} per arm for DC

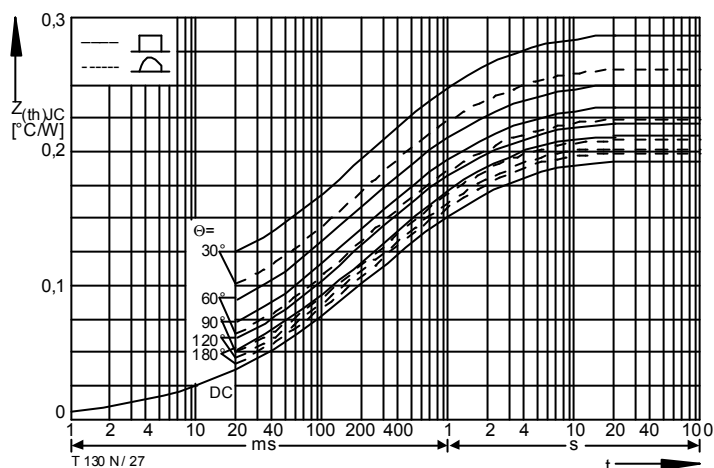
Pos. n	1	2	3	4	5	6	7	8	9
R_{thn} [°C/W]	0,00832	0,0243	0,0373	0,0185	0,037	0,00058	0,0152	0,0353	0,0152
τ_n [s]	0,00089	0,0171	0,0905	0,27	0,413	0,616	0,74	2,16	3

Analytische Funktion / Analytical function:

$$Z_{thJC} = \sum_{n=1}^{n_{max}} R_{thn} (1 - e^{-\frac{t}{\tau_n}})$$