

Technische Information / Technical Information

eupec

Netz Thyristor
Phase Control Thyristor

T 2351N 48...52TOH

N



Vorläufige Daten Preliminary Data

Features:

Volle Sperrfähigkeit bei 125° mit 50 Hz

Full blocking capability at 125°C with 50 Hz

Hohe Stoßströme und niedriger Wärme -
widerstand durch NTV Verbindung
zwischen Silizium und Mo - Trägerscheibe.

High surge currents and low thermal resistance
by using low temperature NTV - connection between
silicon wafer and Molybdänium.

Elektroaktive Passivierung durch a - C:H

Electroactive passivation by a - C:H

Elektrische Eigenschaften / Electrical properties

Höchstzulässige Werte / Maximum rated values

Periodische Vorwärts - und Rückwärts - Spitzensperrspannung repetitive peak forward off-state and reverse voltage	$t_{vj} = -40^{\circ}\text{C} \dots t_{vj\text{ max}}$ $f = 50\text{ Hz}$	$V_{\text{DRM}}, V_{\text{RRM}}$	4800 5000 5200	V V V	
Periodische Vorwärts - und Rückwärts - Spitzensperrspannung repetitive peak forward off-state and reverse voltage	$t_{vj} = +5^{\circ}\text{C} \dots t_{vj\text{ max}}$ $f = 50\text{ Hz}$	$V_{\text{DRM}}, V_{\text{RRM}}$	5500	V	1)
Durchlaßstrom-Grenzeffektivwert RMS forward current		I_{TRMSM}	5000	A	
Dauergrenzstrom mean forward current	$t_{\text{C}} = 85^{\circ}\text{C}, f = 50\text{Hz}$ $t_{\text{C}} = 60^{\circ}\text{C}, f = 50\text{Hz}$	I_{TAVM}	2350 3200	A A	
Stoßstrom-Grenzwert surge forward current	$t_{vj} = 25^{\circ}\text{C}, t_p = 10\text{ms}, V_R = 0$ $t_{vj} = t_{vj\text{ max}}, t_p = 10\text{ms}, V_R = 0$	I_{FSM}	55 54	kA kA	
Grenzlastintegral I^2t -value	$t_{vj} = 25^{\circ}\text{C}, t_p = 10\text{ms}$ $t_{vj} = t_{vj\text{ max}}, t_p = 10\text{ms}$	I^2t	$15,1 \cdot 10^6$ $14,6 \cdot 10^6$	A^2s A^2s	
Kritische Stromsteilheit critical rate of rise of on-state current	DIN IEC 747-6 $f = 50\text{Hz}, v_D = 0,67 V_{\text{DRM}}$ $i_{\text{GM}} = 3\text{A}, di_G/dt = 6\text{A}/\mu\text{s}$	$(di/dt)_{\text{cr}}$	150	$\text{A}/\mu\text{s}$	
Kritische Spannungssteilheit critical rate of rise of off-state current	$t_{vj} = t_{vj\text{ max}}, v_D = 0,67 V_{\text{DRM}}$ 5. Kennbuchstabe / 5 th letter H	$(dv/dt)_{\text{cr}}$	2000	$\text{V}/\mu\text{s}$	

1) auf Anfrage / on request

Charakteristische Werte / Characteristic values

Durchlaßspannung on-state voltage	$t_{vj} = t_{vj\text{ max}}, i_T = 3\text{kA}$	v_T	typ 1,7	max 1,85	V
Schleusenspannung / threshold voltage Ersatzwiderstand / slope resistance	$t_{vj} = t_{vj\text{ max}}$	$V_{\text{(TO)}}$ r_T	typ 0,7 0,37	max 0,81 0,36	V $\text{m}\Omega$
Durchlaßrechenkennlinien On - state characteristics for calculation $V_T = A + B \cdot i_T + C \cdot \ln(i_T+1) + D \cdot \sqrt{i_T}$	$t_{vj} = t_{vj\text{ max}}$	A B C D	typ 0,452 0,000106 -0,0063 0,0179	max -0,109 0,000195 0,139 0,00471	



Vorläufige Daten Preliminary Data

Elektrische Eigenschaften / Electrical properties

Höchstzulässige Werte / Maximum rated values

Zündstrom gate trigger current	$t_{vj} = 25^\circ\text{C}, V_D = 6\text{V}$	I_{GT}	max	350	mA
Zündspannung gate trigger voltage	$t_{vj} = 25^\circ\text{C}, V_D = 6\text{V}$	V_{GT}	max	2,5	V
Nicht zündender Steuerstrom gate non-trigger current	$t_{vj} = t_{vj\text{ max}}, V_D = 6\text{V}$ $t_{vj} = t_{vj\text{ max}}, V_D = 0,5 V_{DRM}$	I_{GD}		20 10	mA mA
nicht zündende Steuerspannung gate non-trigger voltage	$t_{vj} = 25^\circ\text{C}, V_D = 0,5 V_{DRM}$	V_{GD}		0,4	V

Charakteristische Werte / Characteristic values

Haltestrom holding current	$t_{vj} = 25^\circ\text{C}, V_D = 12\text{V}, R_A = 4,7\Omega$	I_H		350	mA
Einraststrom latching current	$t_{vj} = 25^\circ\text{C}, V_D = 12\text{V}, R_{GK} \geq 10\Omega$ $i_{GM} = 3\text{A}, di_G/dt = 6\text{ A}/\mu\text{s}, t_g = 20\mu\text{s}$	I_L	max	3	A
Vorwärts- und Rückwärts-Sperrstrom forward off-state and reverse currents	$t_{vj} = t_{vj\text{ max}}$ $V_D = V_{DRM}, V_R = V_{RRM}$	i_D, i_R		200	mA
Zündverzug gate controlled delay time	DIN IEC 747-6 $t_{vj} = 25^\circ\text{C},$ $i_{GM} = 3\text{A}, di_G/dt = 6\text{A}/\mu\text{s}$	t_{gd}		2	μs
Freiwerdezeit circuit commutated turn-off time	$t_{vj} = t_{vj\text{ max}}, I_{TM} = I_{TAVM}$ $V_{RM} = 100\text{V}, v_{DM} = 0,67 V_{DRM}$ $dv_D/dt = 20\text{V}/\mu\text{s}, -di_T/dt = 10\text{A}/\mu\text{s}$ 4. Kennbuchstabe / 4 th letter O	t_q	typ	450	μs
Sperrverzögerungsladung recovered charge	$t_{vj} = t_{vj\text{ max}}$ $I_{TM} = 2\text{ kA}, di/dt = 10\text{ A}/\mu\text{s}$ $V_R = 0,5 V_{RRM}, V_{RM} = 0,8 V_{RRM}$	Q_r	typ. Max.	20	mAs
Rückstromspitze peak reverse recovery current	$t_{vj} = t_{vj\text{ max}}$ $I_{TM} = 2\text{ kA}, di/dt = 10\text{ A}/\mu\text{s}$ $V_R = 0,5 V_{RRM}, V_{RM} = 0,8 V_{RRM}$	I_{RM}			A

Netz Thyristor
Phase Control Thyristor

T 2351N 48...52TOH

N



Vorläufige Daten Preliminary Data

Thermische Eigenschaften / Thermal properties

Innerer Wärmewiderstand thermal resistance, junction to case	beidseitig / two-sided, $\Theta = 180^\circ\text{sin}$ beidseitig / two-sided, DC	R_{thJC}	0,0063 0,006	$^\circ\text{C/W}$ $^\circ\text{C/W}$
Übergangs-Wärmewiderstand thermal resistance, case to heatsink	beidseitig / two-sided	R_{thCK}	0,002	$^\circ\text{C/W}$
Höchstzulässige Sperrschichttemperatur max. junction temperature		$t_{vj\ max}$	125	$^\circ\text{C}$
Betriebstemperatur operating temperature		$t_{c\ op}$	-40...+125	$^\circ\text{C}$
Lagertemperatur storage temperature		t_{stg}	-40...+150	$^\circ\text{C}$

Mechanische Eigenschaften / Mechanical properties

Gehäuse, siehe Anlage case, see appendix			Seite 4	
Si-Element mit Druckkontakt, Amplifying-Gate Si-pellet with pressure contact, amplifying gate			88TN52	
Anpreßkraft clampig force		F	45...65	kN
Gewicht weight		G	typ 1500	g
Kriechstrecke creepage distance				mm
Feuchtklasse humidity classification	DIN 40040		C	
Schwingfestigkeit vibration resistance	f = 50Hz		50	m/s^2

Mit dieser technischen Information werden Halbleiterbauelemente spezifiziert, jedoch keine Eigenschaften zugesichert. Sie gilt in Verbindung mit den zugehörigen technischen Erläuterungen.
This technical information specifies semiconductor devices but promises no characteristics. It is valid in combination with the belonging technical notes.



Outline Drawing

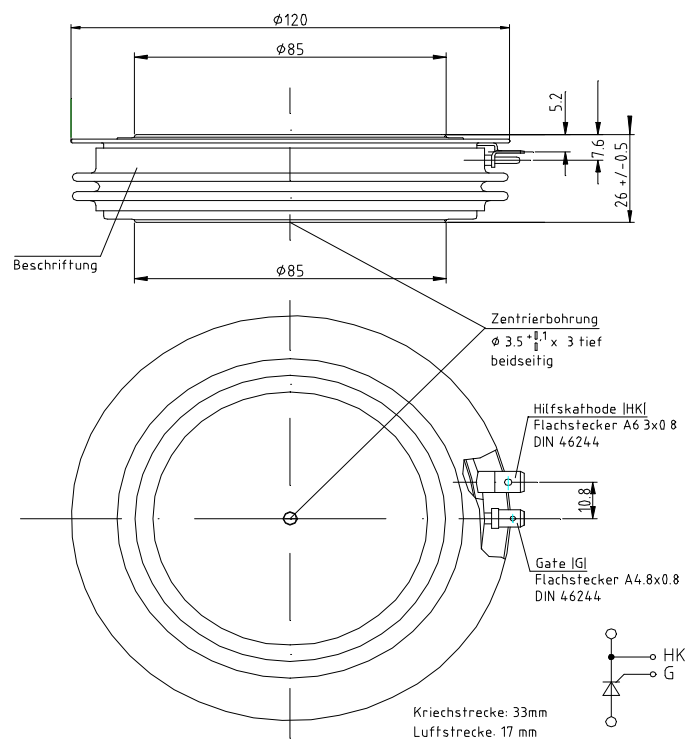

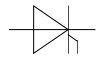

Vorläufige Daten
Preliminary Data

Durchlaßkennlinie $i_T = f(v_T)$
Limiting and typical on-state characteristic

$\frac{3}{4}$ $t_{vj} = 125^\circ \text{C}$

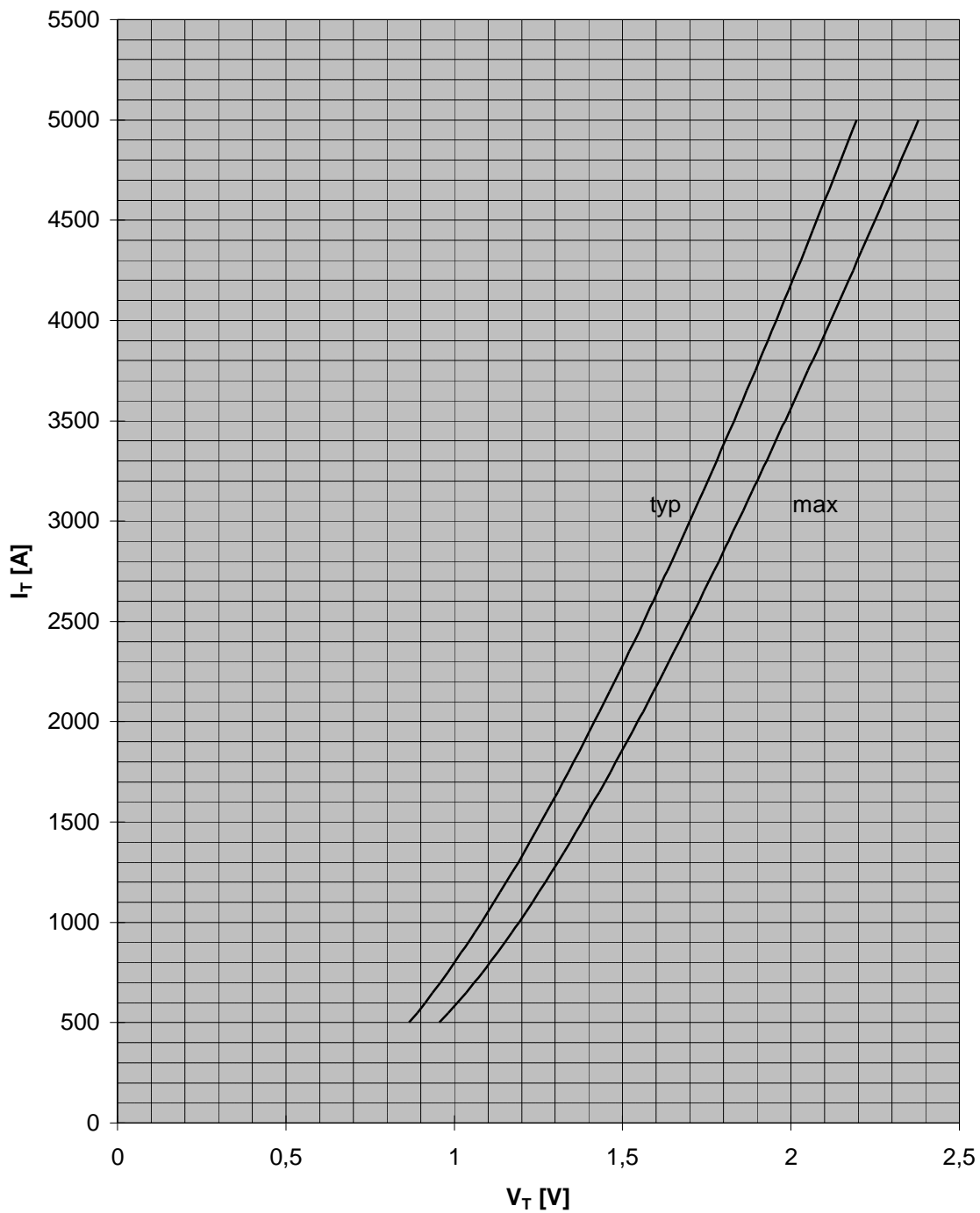

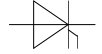

Vorläufige Daten
Preliminary Data

Transienter innerer Wärmewiderstand
Transient thermal impedance $Z_{(th)JC} = f(t)$
Parameter: Stromflußwinkel / Current conduction angle

	doppe seitige Kühlung		anodenseitige Kühlung		kathodenseitige Kühlung	
	r [K/W]	[s]	r [K/W]	[s]	r [K/W]	[s]
1	0,0009	1,47	0,0052	8,15	0,0072	10,6
2	0,0015	0,27	0,0022	0,4	0,0022	0,4
3	0,00083	0,16	0,00083	0,16	0,00083	0,16
4	0,0023	0,1	0,0023	0,1	0,0023	0,1
5	0,00047	0,004	0,00047	0,004	0,00047	0,004
	0,006	-	0,011	-	0,013	-

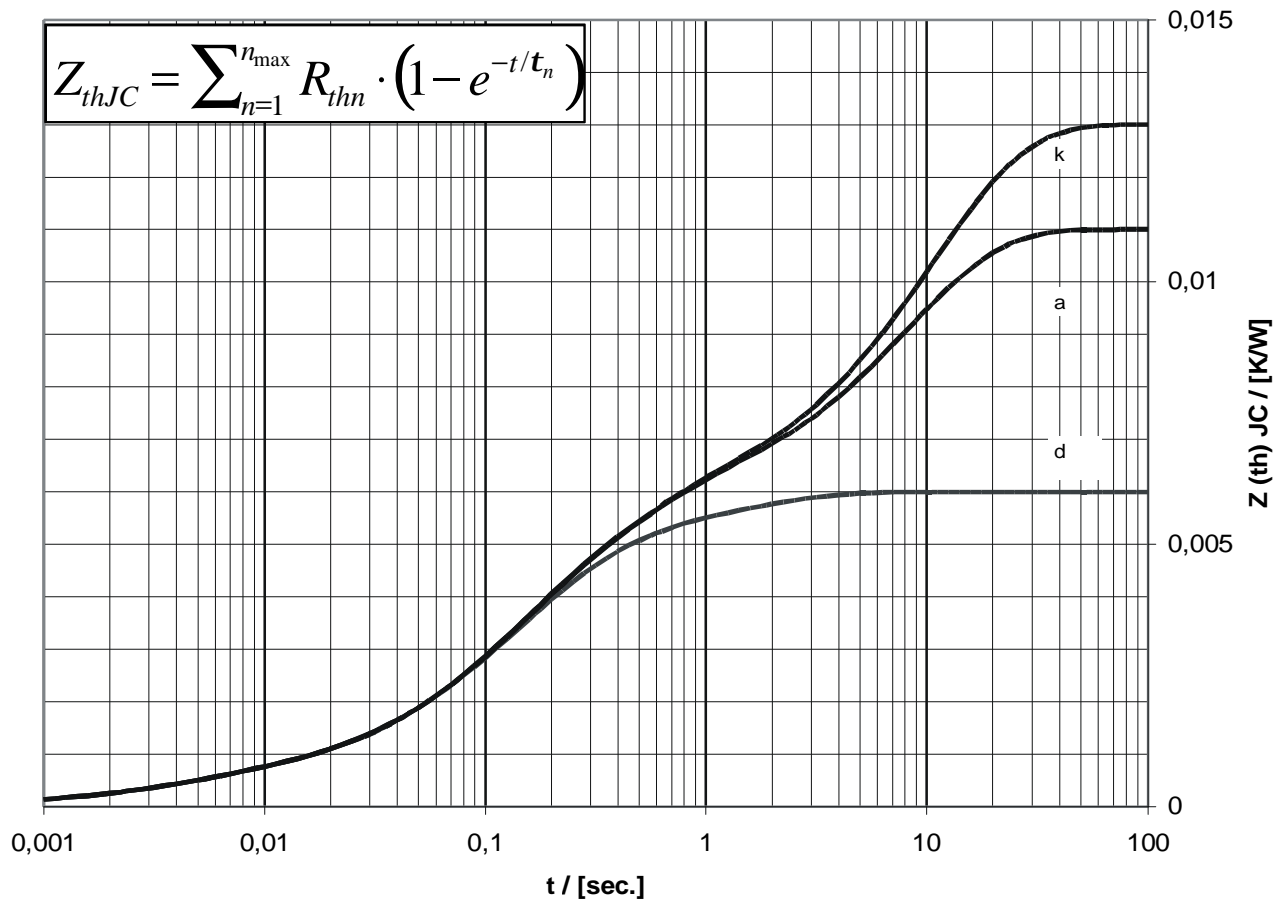



Vorläufige Daten
Preliminary Data

Sperrverzögerungsladung $Q_r = f(-di/dt)$
recovered charge

$t_{vj} = 125^\circ\text{C}, I_{TM} = 2000\text{A},$
 $V_R = 0,5 V_{RRM}, V_{RM} = 0,8 V_{RRM}$

