

# Technische Information / Technical Information

**eupec**

Netz Thyristor

Phase Control Thyristor

## T 2561N 75 TOH

Vorläufige Daten / Provisional Data

**N**

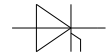

### Elektrische Eigenschaften / Electrical properties

#### Höchstzulässige Werte / Maximum rated values

Periodische Rückwärts-Spitzensperrspannung repetitive peak reverse voltage	$t_{vj} = -40^{\circ}\text{C} \dots t_{vj\text{ max}}$	$V_{RRM}$	8000 7500	V V
Durchlaßstrom-Grenzeffektivwert RMS forward current		$I_{TRMSM}$	5600	A
Dauergrenzstrom mean forward current	$t_C = 85^{\circ}\text{C}, f = 50\text{Hz}$ $t_C = 60^{\circ}\text{C}, f = 50\text{Hz}$	$I_{TAVM}$	2560 3570	A A
Stoßstrom-Grenzwert surge forward current	$t_{vj} = 25^{\circ}\text{C}, t_p = 10\text{ms}$ $t_{vj} = t_{vj\text{ max}}, t_p = 10\text{ms}$	$I_{TSM}$	63 56	kA kA
Grenzlastintegral $I^2t$ -value	$t_{vj} = 25^{\circ}\text{C}, t_p = 10\text{ms}$ $t_{vj} = t_{vj\text{ max}}, t_p = 10\text{ms}$	$I^2t$	$19,8 \cdot 10^6$ $15,7 \cdot 10^6$	$\text{A}^2\text{s}$ $\text{A}^2\text{s}$
Kritische Stromsteilheit, periodisch critical rate of rise of on-state current, periodical	DIN IEC 747-6 $f = 50\text{Hz}, v_D = 0,67 V_{DRM}, i_{GM} = 3\text{A},$ $di_G/dt = 6\text{A}/\mu\text{s}$	$(di/dt)_{cr}$	150	$\text{A}/\mu\text{s}$
Kritische Spannungssteilheit critical rate of rise of off-state current	$t_{vj} = t_{vj\text{ max}}, v_{DM} = 5\text{kV}$	$(dv/dt)_{cr}$	2000	$\text{V}/\mu\text{s}$

#### Charakteristische Werte / Characteristic values

Durchlaßspannung on-state voltage	$t_{vj} = t_{vj\text{ max}}, i_T = 6\text{kA}$	$V_T$	typ. 2,75	max. 2,95	V
Schleusenspannung / threshold voltage Ersatzwiderstand / slope resistance	$t_{vj} = t_{vj\text{ max}}$	$V_{TO}$ $r_T$	typ. 1,23 0,253	max. 1,28 0,278	V $\text{m}\Omega$
Durchlaßrechenkennlinie on-state characteristics for calculations $V_T = A + B \cdot i_T + C \cdot \ln(i_T + 1) + D \cdot \sqrt{i_T}$	$t_{vj} = t_{vj\text{ max}}$	A B C D	typ. -0,00607 0,000181 0,162 0,00342	max. -0,00503 0,000187 0,160 0,00570	
Zündstrom gate trigger current	$t_{vj} = 25^{\circ}\text{C}, v_D = 6\text{V}$	$I_{GT}$	max	350	$\text{mA}$
Zündspannung gate trigger voltage	$t_{vj} = 25^{\circ}\text{C}, v_D = 6\text{V}$	$V_{GT}$	max	2,5	V
Nicht zündender Steuerstrom gate non-trigger current	$t_{vj} = t_{vj\text{ max}}, v_D = 6\text{V}$ $t_{vj} = t_{vj\text{ max}}, v_D = 0,5 \cdot V_{DRM}$	$I_{GD}$		20 10	$\text{mA}$ $\text{mA}$
nicht zündende Steuerspannung gate non-trigger voltage	$t_{vj} = 25^{\circ}\text{C}, v_D = 0,5 V_{DRM}$	$V_{GD}$		0,4	V

# Technische Information / Technical Information

**eupec**

Netz Thyristor

Phase Control Thyristor

## T 2561N 75 TOH

Vorläufige Daten / Provisional Data

**N**

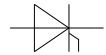

### Elektrische Eigenschaften / Electrical properties

#### Charakteristische Werte / Characteristic values

Haltestrom holding current	$t_{vj} = 25^{\circ}\text{C}, v_D = 12\text{V}, R_A = 4,7\Omega$	$I_H$	350	mA
Einraststrom latching current	$t_{vj} = 25^{\circ}\text{C}, v_D = 12\text{V}, R_{GK} \geq 10\Omega$ $i_{GM} = 3\text{A}, di_G/dt = 6\text{A}/\mu\text{s}, t_g = 20\mu\text{s}$	$I_L$	max. 3	A
Vorwärts- und Rückwärts-Sperrstrom forward off-state and reverse currents	$t_{vj} = t_{vj\text{ max}}$ $v_D = V_{DRM}, v_R = V_{RRM}$	$i_D, i_R$	max. 900	mA
Zündverzögerung gate controlled delay time	DIN IEC 747-6 $t_{vj} = 25^{\circ}\text{C},$ $i_{GM} = 3\text{A}, di_G/dt = 6\text{A}/\mu\text{s}$	$t_{gd}$	typ. 2,5	$\mu\text{s}$
Freiwerdezeit circuit commutated turn-off time	$t_{vj} = t_{vj\text{ max}}, i_{TM} = I_{TAVM}$ $V_{RM} = 100\text{V}, v_{DM} = 0,67 \cdot V_{DRM}$ $dv_D/dt = 20\text{V}/\mu\text{s}, -di_T/dt = 10\text{A}/\mu\text{s}$ 4. Kennbuchstabe / 4 <sup>th</sup> letter O	$t_q$	typ. 550	$\mu\text{s}$
Sperrverzögerungsladung recovered charge	$t_{vj} = t_{vj\text{ max}}$ $I_{TM} = 4000\text{A}, di/dt = 10\text{A}/\mu\text{s}$ $V_R = 0,5 \cdot V_{RRM}, V_{RM} = 0,8 \cdot V_{RRM}$	$Q_r$	max. 19	mAs
Rückstromspitze peak reverse recovery current	$t_{vj} = t_{vj\text{ max}}$ $I_{TM} = 4000\text{A}, di/dt = 10\text{A}/\mu\text{s}$ $V_R = 0,5 \cdot V_{RRM}, V_{RM} = 0,8 \cdot V_{RRM}$	$I_{RM}$	max. 400	A

# Technische Information / Technical Information

**eupec**

Netz Thyristor

Phase Control Thyristor

## T 2561N 75 TOH

Vorläufige Daten / Provisional Data

**N**

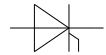

### Thermische Eigenschaften / Thermal properties

Innerer Wärmewiderstand thermal resistance, junction to case	Kühlfläche / cooling surface beidseitig / two-sided, $\theta = 180^\circ\text{sin}$ beidseitig / two sided, DC	$R_{thJC}$	0,0046 0,0043	$^\circ\text{C/W}$ $^\circ\text{C/W}$
Übergangs-Wärmewiderstand thermal resistance, case to heatsink	Kühlfläche / cooling surface beidseitig / two-sided	$R_{thCK}$	0,0010	$^\circ\text{C/W}$
Höchstzulässige Sperrschichttemperatur max. junction temperature		$t_{vj\ max}$	+125	$^\circ\text{C}$
Betriebstemperatur operating temperature		$t_{c\ op}$	0...+125	$^\circ\text{C}$
Lagertemperatur storage temperature		$t_{stg}$	-40...+150	$^\circ\text{C}$

### Mechanische Eigenschaften / Mechanical properties

Gehäuse, siehe Anlage case, see appendix			Seite 4	
Si-Element mit Druckkontakt, Lichtzündung Si-pellet with pressure contact, light triggered	Silizium Tablette silicon wafer		119TN80	
Anpreßkraft clampig force		F	90...130	kN
Gewicht weight		G	typ. 4000	g
Kriechstrecke creepage distance			33	mm
Feuchteklasse humidity classification	DIN 40040		C	
Schwingfestigkeit vibration resistance	f = 50Hz		50	$\text{m/s}^2$

Mit dieser technischen Information werden Halbleiterbauelemente spezifiziert, jedoch keine Eigenschaften zugesichert. Sie gilt in Verbindung mit den zugehörigen technischen Erläuterungen.  
This technical information specifies semiconductor devices but promises no characteristics. It is valid in combination with the belonging technical notes.

Netz Thyristor

Phase Control Thyristor

## T 2561N 75 TOH

Vorläufige Daten / Provisional Data

**N**

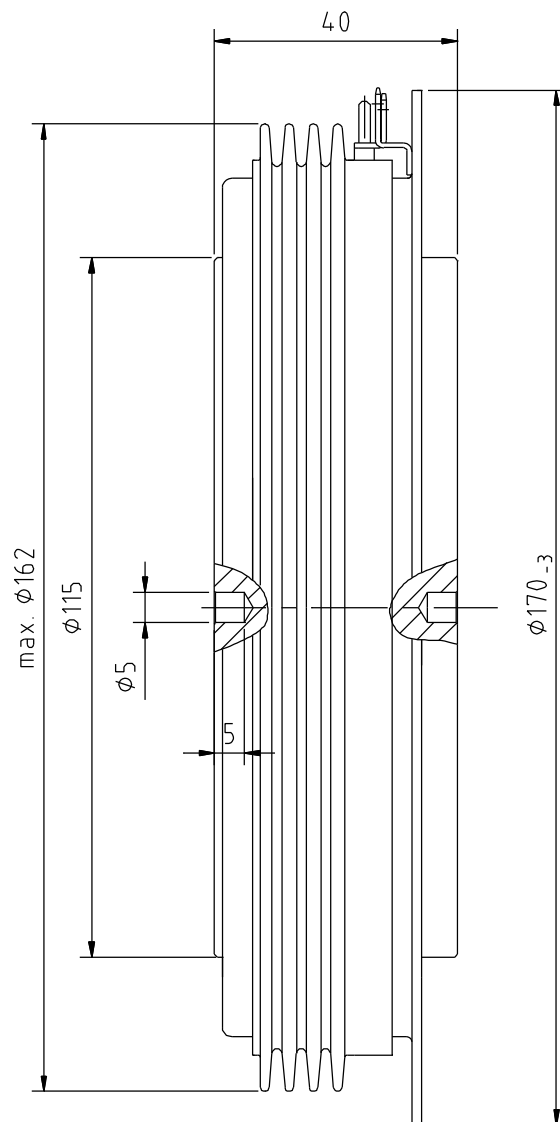
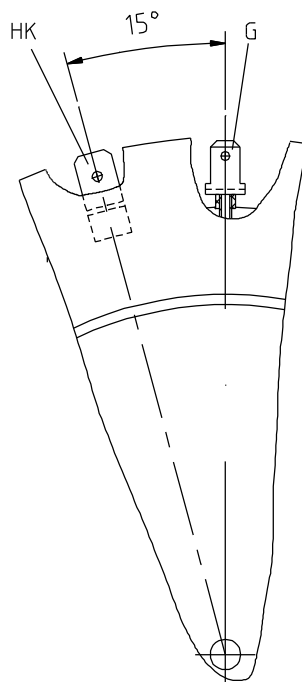
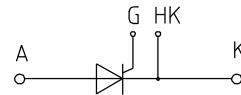
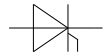

G: Flachstecker A4.8x0.8  
nach DIN 46244

HK: Flachstecker A6.3x0.8  
nach DIN 46244

Kriechstrecke: 49mm  
Anpresskraft 90 - 130 kN

Netz Thyristor

Phase Control Thyristor

# T 2561N 75 TOH

Vorläufige Daten / Provisional Data

N

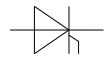

## Durchlaßkennlinien $i_T = f(v_T)$ Limiting and typical on-state characteristic

$t_{vj} = 125^\circ\text{C}$

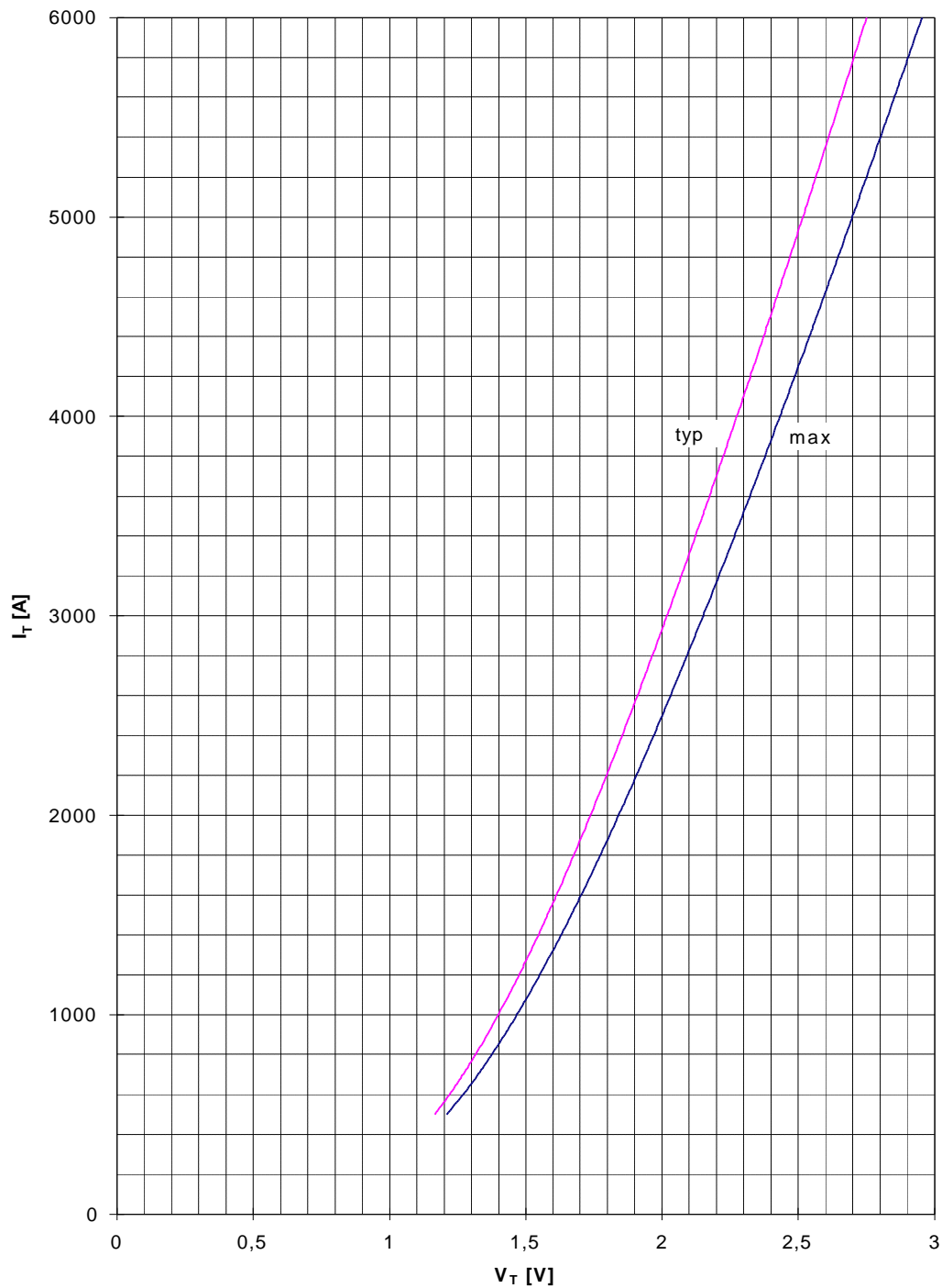

Netz Thyristor

Phase Control Thyristor

T 2561N 75 TOH

Vorläufige Daten / Provisional Data

N

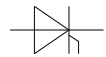

**Sperrverzögerungsladung  $Q_{rr} = f(-di/dt)$**   
 recovered charge

Nebenbedingungen:  $t_{vj} = 125^{\circ}\text{C}$ ,  $I_{TM} = 4000\text{A}$ ,  $v_R = 0,5 \cdot V_{RRM}$ ,  $v_{RM} = 0,8 \cdot V_{RRM}$

