

Netz Thyristor  
Phase Control Thyristor

## T 501 N 60...70 TOH

**N**

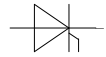

Vorläufige Daten / Preliminary Data

### Features:

Volle Sperrfähigkeit bei 125° mit 50 Hz

Full blocking capability at 125°C with 50 Hz

Hohe Stoßströme und niedriger Wärme-  
widerstände durch NTV-Verbindung  
zwischen Silizium und Mo-Trägerscheibe.

High surge currents and low thermal resistance  
by using low temperature-connection NTV  
between silicon wafer and molybdenum.

Elektroaktive Passivierung durch a - C:H

Electroactive passivation by a - C:H

### Elektrische Eigenschaften / Electrical properties

Höchstzulässige Werte / Maximum rated values

Periodische Vorwärts- und Rückwärts-Spitzensperrspannung repetitive peak forward off-state and reverse voltage	$t_{vj} = -40^{\circ}\text{C} \dots t_{vj\text{ max}}$	$V_{\text{DRM}}, V_{\text{RRM}}$	6000 6500 7000	V V V
Durchlaßstrom-Grenzeffektivwert RMS forward current		$I_{\text{TRMSM}}$	1350	A
Dauergrenzstrom mean forward current	$t_c = 85^{\circ}\text{C}, f = 50\text{Hz}$ $t_c = 60^{\circ}\text{C}, f = 50\text{Hz}$	$I_{\text{TAVM}}$	640 860	A A
Stoßstrom-Grenzwert surge forward current	$t_{vj} = 25^{\circ}\text{C}, t_p = 10\text{ms}$ $t_{vj} = t_{vj\text{ max}}, t_p = 10\text{ms}$	$I_{\text{TSM}}$	12,5 12,0	kA kA
Grenzlastintegral $I^2t$ -value	$t_{vj} = 25^{\circ}\text{C}, t_p = 10\text{ms}$ $t_{vj} = t_{vj\text{ max}}, t_p = 10\text{ms}$	$I^2t$	$780 \cdot 10^3$ $720 \cdot 10^3$	$\text{A}^2\text{s}$ $\text{A}^2\text{s}$
Kritische Stromsteilheit critical rate of rise of on-state current	DIN IEC 747-6 $f = 50\text{Hz}, v_D = 0,67 V_{\text{DRM}}, i_{\text{GM}} = 3\text{A},$ $di/dt = 6\text{A}/\mu\text{s}$	$(di/dt)_{\text{cr}}$	300	$\text{A}/\mu\text{s}$
Kritische Spannungssteilheit critical rate of rise of off-state current	$t_{vj} = t_{vj\text{ max}}, v_D = 0,67 V_{\text{DRM}}$ 5. Kennbuchstabe / 5 th letter F	$(dv/dt)_{\text{cr}}$	2000	$\text{V}/\mu\text{s}$

### Charakteristische Werte / Characteristic values

Durchlaßspannung on-state voltage	$t_{vj} = t_{vj\text{ max}}, i_T = 1\text{kA}$	$V_T$	typ. 2,55	max. 2,65	V
Schleusenspannung / threshold voltage Ersatzwiderstand / slope resistance	$t_{vj} = t_{vj\text{ max}}$ 600A / 2000A	$V_{(TO)}$ $r_T$	typ. 1,175 1,336	max. 1,212 1,395	V $\text{m}\Omega$
Durchlaßrechenkennlinie on - state characteristics for calculation $V_T = A + B \cdot i_T + C \cdot \ln(i_T + 1) + D \cdot \sqrt{i_T}$	$t_{vj} = t_{vj\text{ max}}$	A B C D	typ. -0,2795 0,001067 0,2398 0,003362	max. 0,0129 0,001006 0,1622 0,0161	
Zündstrom gate trigger current	$t_{vj} = 25^{\circ}\text{C}, v_D = 6\text{V}$	$I_{\text{GT}}$	max	300	mA
Zündspannung gate trigger voltage	$t_{vj} = 25^{\circ}\text{C}, v_D = 6\text{V}$	$V_{\text{GT}}$	max	2,5	V
Nicht zündender Steuerstrom gate non-trigger current	$t_{vj} = t_{vj\text{ max}}, v_D = 6\text{V}$ $t_{vj} = t_{vj\text{ max}}, v_D = 0,5 \cdot V_{\text{DRM}}$	$I_{\text{GD}}$		20 10	mA mA
nicht zündende Steuerspannung gate non-trigger voltage	$t_{vj} = 25^{\circ}\text{C}, v_D = 0,5 V_{\text{DRM}}$	$V_{\text{GD}}$		0,4	V

Netz Thyristor  
Phase Control Thyristor

## T 501 N 60...70 TOH

**N**



Vorläufige Daten / Preliminary Data

### Elektrische Eigenschaften / Electrical properties

#### Charakteristische Werte / Characteristic values

Haltestrom holding current	$t_j = 25^\circ\text{C}, v_D = 12\text{V}, R_A = 4,7\Omega$	$I_H$	350	mA
Einraststrom latching current	$t_j = 25^\circ\text{C}, v_D = 12\text{V}, R_{GK} \geq 10\Omega$ $i_{GM} = 3\text{A}, di_G/dt = 6\text{A}/\mu\text{s}, t_g = 20\mu\text{s}$	$I_L$	max. 3	A
Vorwärts- und Rückwärts-Sperrstrom forward off-state and reverse currents	$t_j = t_{j,max}$ $v_D = V_{DRM}, V_R = V_{RRM}$	$i_D, i_R$	max. 200	mA
Zündverzugszeit gate controlled delay time	DIN IEC 747-6 $t_j = 25^\circ\text{C},$ $i_{GM} = 3\text{A}, di_G/dt = 6\text{A}/\mu\text{s}$	$t_{gd}$	2,5	$\mu\text{s}$
Freiwerdezeit circuit commutated turn-off time	$t_j = t_{j,max}, i_{TM} = I_{TAVM}$ $V_{RM} = 100\text{V}, v_{DM} = 0,67 V_{DRM}$ $dv_D/dt = 20\text{V}/\mu\text{s}, -di_T/dt = 10\text{A}/\mu\text{s}$ 4. Kennbuchstabe / 4 th letter O	$t_q$	typ. 650	$\mu\text{s}$
Sperrverzögerungsladung recovered charge	$t_j = t_{j,max}$ $I_{TM} = 2000\text{A}, di/dt = 10\text{A}/\mu\text{s}$ $V_R = 0,5 V_{RRM}, V_{RM} = 0,8 V_{RRM}$	$Q_r$	max. 7	mAs
Rückstromspitze peak reverse recovery current	$t_j = t_{j,max}$ $I_{TM} = 2000\text{A}, di/dt = 10\text{A}/\mu\text{s}$ $V_R = 0,5 \cdot V_{RRM}, V_{RM} = 0,8 \cdot V_{RRM}$	$I_{RM}$	max. 180	A

Netz Thyristor  
Phase Control Thyristor

## T 501 N 60...70 TOH

**N**



Vorläufige Daten / Preliminary Data

### Thermische Eigenschaften / Thermal properties

Innerer Wärmewiderstand thermal resistance, junction to case	beidseitig / two-sided, sin 180° beidseitig / two-sided, DC	R <sub>thJC</sub>	0,0185 0,0170	K/W K/W
Übergangs-Wärmewiderstand thermal resistance, case to heatsink	beidseitig / two-sided	R <sub>thCH</sub>	0,005	K/W
Höchstzulässige Sperrschichttemperatur max. junction temperature		t <sub>vj max</sub>	125	°C
Betriebstemperatur operating temperature		t <sub>c op</sub>	-40...+125	°C
Lagertemperatur storage temperature		t <sub>stg</sub>	-40...+150	°C

### Mechanische Eigenschaften / Mechanical properties

Gehäuse, siehe Anlage case, see appendix			Seite 4	
Si - Element mit Druckkontakt, Amplifying gate Si - pellet with pressure contact, amplifying gate	Silizium Tablette silicon wafer		55TN70	
Anpreßkraft clamp force		F	15..24	kN
Gewicht weight		G	typ. 550	g
Kriechstrecke surface creepage distance			25	mm
Feuchtklasse humidity classification	DIN 40040		C	
Schwingfestigkeit vibration resistance	f = 50Hz		50	m/s <sup>2</sup>

Mit dieser technischen Information werden Halbleiterbauelemente spezifiziert, jedoch keine Eigenschaften zugesichert. Sie gilt in Verbindung mit den zugehörigen technischen Erläuterungen.  
This technical information specifies semiconductor devices but promises no characteristics. It is valid in combination with the belonging technical notes.

Netz Thyristor  
Phase Control Thyristor

T 501 N 60...70 TOH

N



Vorläufige Daten / Preliminary Data

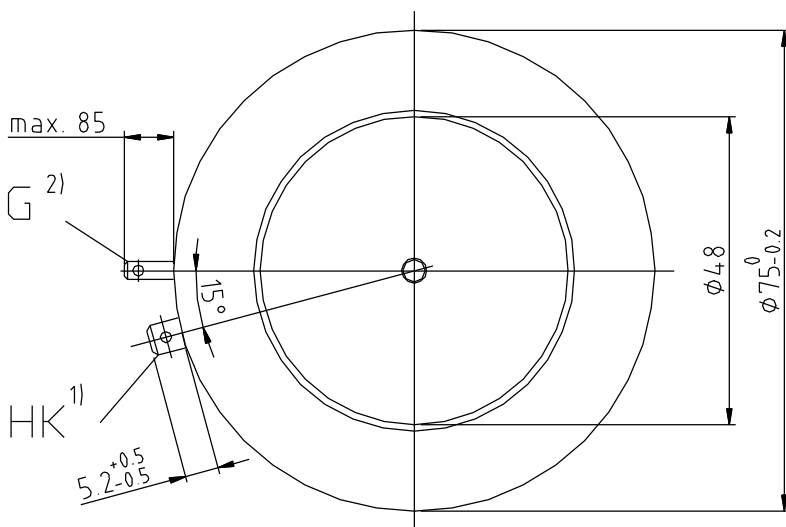
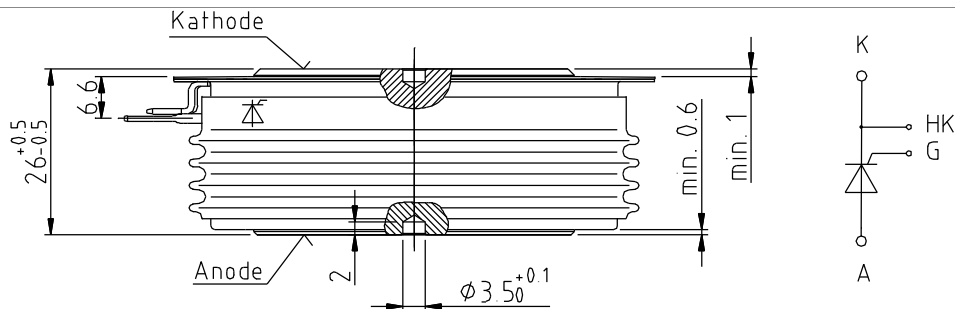

Gewicht: ca.550g

Kriechstrecke:	A,K = 25mm
	A,G = 25mm
	G,K = 1mm

G 1) Flachstecker A2.8x0.8 nach DIN 46244

HK 2) Flachstecker 4.8x0.4 nach DIN 46244

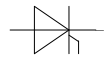

Durchlaßkennlinien / on-state characteristic

$$i_T = f(v_T)$$

$$t_{vj} = 125^\circ\text{C}$$

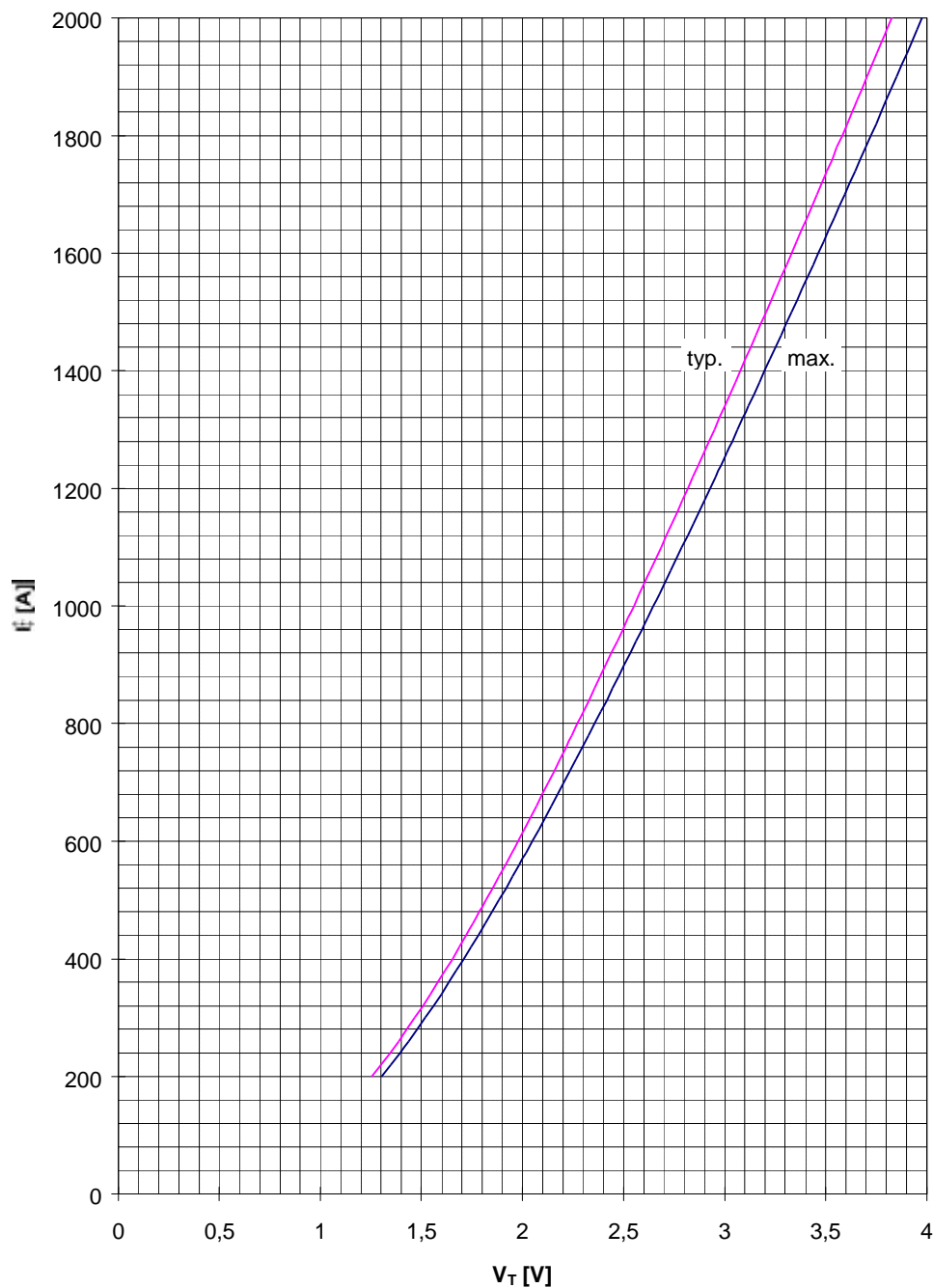

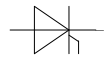

**Transienter innerer Wärmewiderstand**  
**Transient thermal impedance  $Z_{th JC} = f(t)$**

$$Z_{th JC}(t) = \sum_n R_{th n} \cdot (1 - e^{-t/\tau_n})$$

n	beidseitige Kühlung / double sided cooling		kathodenseitige Kühlung / cathode sided cooling		anodenseitige Kühlung / anode sided cooling	
	$R_{th n}$ [K/W]	$\tau_n$ [s]	$R_{th n}$ [K/W]	$\tau_n$ [s]	$R_{th n}$ [K/W]	$\tau_n$ [s]
1	0,00848	0,6758	0,02807	4,1303	0,01917	4,1291
2	0,00243	0,1323	0,00106	0,4522	0,00232	0,3996
3	0,00304	0,0623	0,00487	0,1255	0,00280	0,1537
4	0,00272	0,0134	0,00237	0,0374	0,00366	0,0607
5	0,00033	0,0019	0,00210	0,0091	0,00254	0,0101
S	<b>0,0170</b>	-	<b>0,03847</b>	-	<b>0,0305</b>	-

Doppelseitige Kühlung / double sided cooling:	add. $R_{th}$ [K/W]
180°-Rechteckstrom / 180° rectangular current:	0,00169
120°-Rechteckstrom / 120° rectangular current:	0,00257
60°-Rechteckstrom / 60° rectangular current:	0,00390
30°-Rechteckstrom / 30° rectangular current:	0,00494
180°-Sinusstrom / 180° sine current:	0,00145

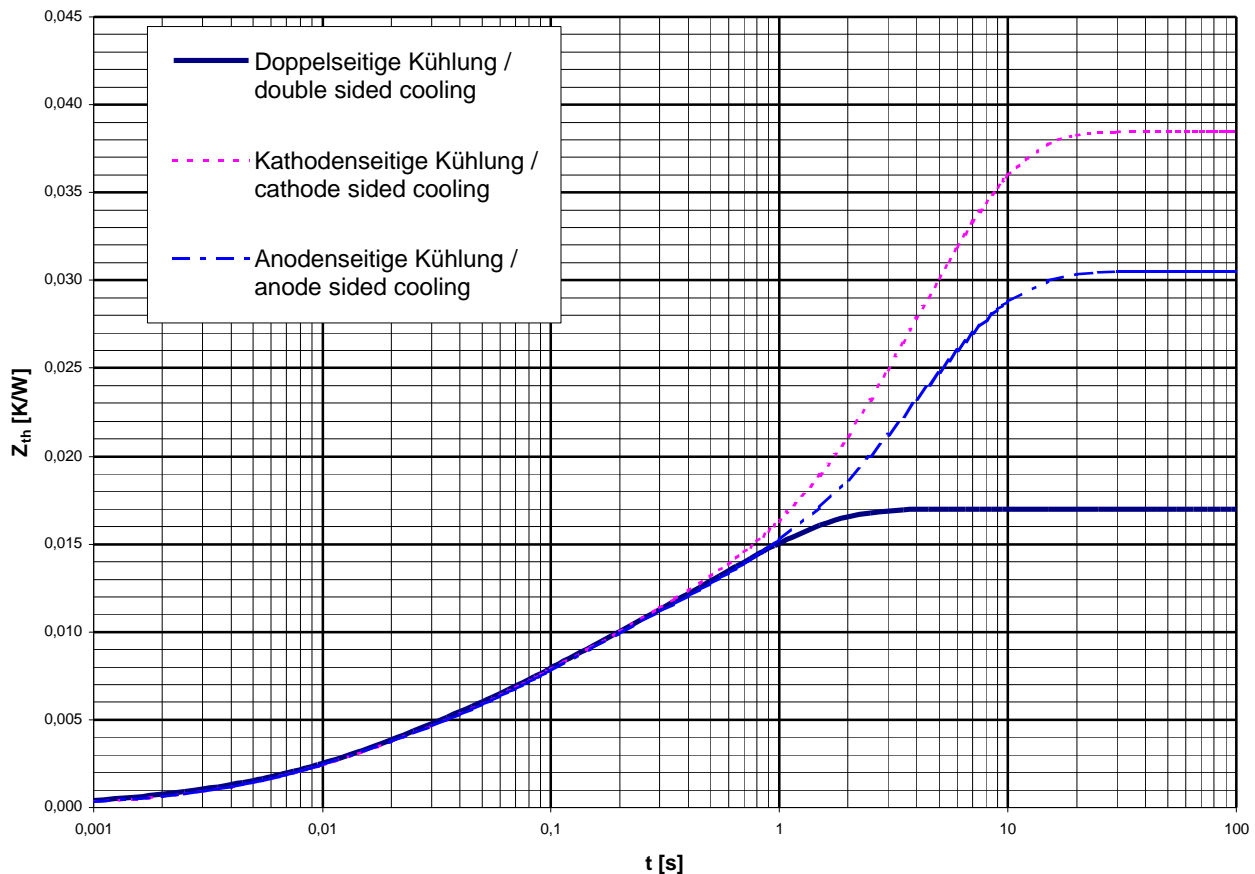

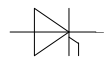

Sperrverzögerungsladung / recoverd charge

$$Q_{rr} = f (di/dt)$$

$t_{vj} = 125^{\circ}C, I_{TM} = 1000A, V_R = 0,5 \cdot V_{RRM}, V_R = 0,8 \cdot V_{RRM}$

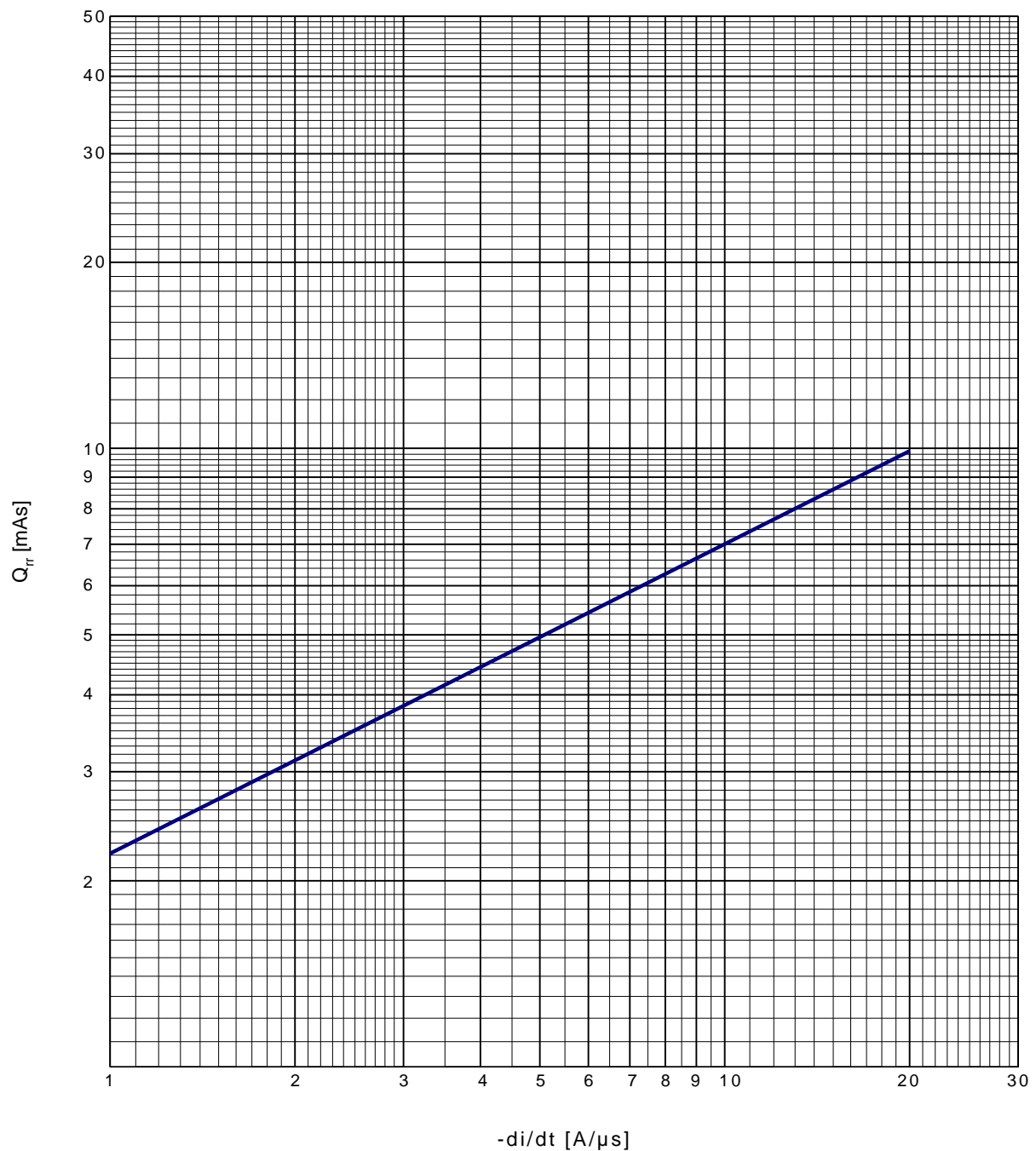

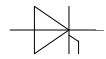

Rückstromspitze / reverse recovery current

$$I_{RM} = f (di/dt)$$

$$t_{vj} = 125^{\circ}C, I_{TM} = 1000A, v_R = 0,5 \cdot V_{RRM}, v_{RM} = 0,8 \cdot V_{RRM}$$

