

Lichtzündbarer Netzthyristor
Light Triggered Phase Control Thyristor

T 553 N 70 TOH

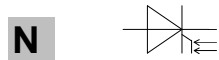

Vorläufige Daten / Provisional Data

Features:

Lichtgezündeter Netz Thyristor mit integriertem. Überspannungsschutz

Volle Sperrfähigkeit bei 120° mit 50 Hz

Hohe Stoßströme und niedriger Widerstände durch NTV-Verbindung zwischen Silizium und Mo-Trägerscheibe.

Elektroaktive Passivierung durch a - C:H

Phase Control Thyristor, light triggered with integrated overvoltage protection

Full blocking capability at 120°C with 50 Hz

High surge currents and low thermal resistance by using low temperature-connection NTV between silicon wafer and molybdenum.

Electroactive passivation by a - C:H

Elektrische Eigenschaften / Electrical properties

Höchstzulässige Werte / Maximum rated values

Periodische Rückwärts-Spitzensperrspannung repetitive peak reverse voltage	$t_{vj} = 0^\circ\text{C} \dots t_{vj\text{ max}}$	V_{RRM}	7000	V
Durchlaßstrom-Grenzeffektivwert RMS forward current		I_{TRMSM}	1220	A
Dauergrenzstrom mean forward current	$t_c = 85^\circ\text{C}, f = 50\text{Hz}$ $t_c = 60^\circ\text{C}, f = 50\text{Hz}$	I_{TAVM}	550 780	A A
Stoßstrom-Grenzwert surge forward current	$t_{vj} = 25^\circ\text{C}, t_p = 10\text{ms}$ $t_{vj} = t_{vj\text{ max}}, t_p = 10\text{ms}$	I_{TSM}	11,5 11	kA kA
Grenzlastintegral I^2t -value	$t_{vj} = 25^\circ\text{C}, t_p = 10\text{ms}$ $t_{vj} = t_{vj\text{ max}}, t_p = 10\text{ms}$	I^2t	$660 \cdot 10^3$ $605 \cdot 10^3$	A^2s A^2s
Kritische Stromsteilheit, periodisch critical rate of rise of on-state current, periodical	DIN IEC 747-6 $V_D \leq V_{BO}, f = 50\text{Hz}, P_L = 40\text{mW},$ $t_{rise} = 0,5\mu\text{s}$	$(di/dt)_{cr}$	300	A/ μs
Kritische Stromsteilheit, nicht-periodisch critical rate of rise of on-state current, non-periodical	DIN IEC 747-6 $V_D \leq V_{BO}, P_L = 40\text{mW}, t_{rise} = 0,5\mu\text{s}$	$(di/dt)_{cr}$	1000	A/ μs
Kritische Spannungssteilheit critical rate of rise of off-state current	$t_{vj} = t_{vj\text{ max}}, V_{DM} = 4,3\text{kV}$	$(dv/dt)_{cr}$	2000	V/ μs

Technische Information / Technical Information

eupec

Lichtzündbarer Netzthyristor
Light Triggered Phase Control Thyristor

T 553 N 70 TOH

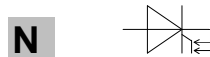

Vorläufige Daten / Provisional Data

Charakteristische Werte / Characteristic values

Schutzzündspannung (statisch) protective break over voltage	$t_{vj} = 0^\circ\text{C} \dots t_{vj \max}$	V_{BO}	min. 6500	V
Durchlaßspannung on-state voltage	$t_{vj} = t_{vj \max}, i_T = 1\text{kA}$	V_T	typ. 2,55 max. 2,65	V
Schleusenspannung / threshold voltage Ersatzwiderstand / slope resistance	$t_{vj} = t_{vj \max}$	V_{TO} r_T	typ. 1,175 max. 1,212 1,336 1,395	V mΩ
Durchlaßrechenkennlinie on-state characteristics for calculations $V_T = A + B \cdot i_T + C \cdot \ln(i_T + 1) + D \cdot \sqrt{i_T}$	$t_{vj} = t_{vj \max}$	A B C D	typ. -0,2795 max. 0,0129 0,001067 0,001006 0,2398 0,1622 0,00336 0,0161	
erforderliche Zündlichtleistung required gate trigger light power	$t_{vj} = 25^\circ\text{C}, v_D = 50\text{V}$	P_{LM}	max. 40	mW
Haltestrom holding current	$t_{vj} = 25^\circ\text{C}$	I_H	100	mA
Einraststrom latching current	$t_{vj} = 25^\circ\text{C}, v_D = 50\text{V},$ $P_{LM} = 40\text{mW}, t_{an} = 0,5\mu\text{s}$	I_L	100	mA
Vorwärts- und Rückwärts-Sperrstrom forward off-state and reverse currents	$t_{vj} = t_{vj \max}$ $v_D = v_R = 7500\text{V}$	i_D, i_R	300	mA
Zündverzug gate controlled delay time	$v_D = 1000\text{V}, t_{vj} = 25^\circ\text{C},$ $P_{LM} = 40\text{mW}, t_{an} = 0,5\mu\text{s}$	t_{gd}	typ. 5	μs
Freiwerdezeit circuit commutated turn-off time	$t_{vj} = t_{vj \max}, i_{TM} = I_{TAVM}$ $V_{RM} = 100\text{V}, v_{DM} = 0,67 \cdot v_{DRM}$ $dv_D/dt = 20\text{V}/\mu\text{s}, -di_T/dt = 10\text{A}/\mu\text{s}$ 4. Kennbuchstabe / 4 th letter O	t_q	typ. 650	μs
Sperrverzögerungsladung recovered charge	$t_{vj} = t_{vj \max}$ $I_{TM} = 4000\text{A}, di/dt = 10\text{A}/\mu\text{s}$ $V_R = 0,5 \cdot V_{RRM}, V_{RM} = 0,8 \cdot V_{RRM}$	Q_r	7	mAs
Rückstromspitze peak reverse recovery current	$t_{vj} = t_{vj \max}$ $I_{TM} = 4000\text{A}, di/dt = 10\text{A}/\mu\text{s}$ $V_R = 0,5 \cdot V_{RRM}, V_{RM} = 0,8 \cdot V_{RRM}$	I_{RM}	190	A

Technische Information / Technical Information

eupec

Lichtzündbarer Netzthyristor
Light Triggered Phase Control Thyristor

T 553 N 70 TOH

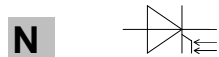

Vorläufige Daten / Provisional Data

Thermische Eigenschaften / Thermal properties

Innerer Wärmewiderstand thermal resistance, junction to case	Kühlfläche / cooling surface beidseitig / two-sided, $\Theta = 180^\circ$ sin beidseitig / two sided, DC	R_{thJC}	0,020 0,019	$^\circ\text{C/W}$ $^\circ\text{C/W}$
Übergangs-Wärmewiderstand thermal resistance, case to heatsink	Kühlfläche / cooling surface beidseitig / two-sided	R_{thCK}	0,005	$^\circ\text{C/W}$
Höchstzulässige Sperrschichttemperatur max. junction temperature		$t_{vj\ max}$	+120	$^\circ\text{C}$
Betriebstemperatur operating temperature		$t_{c\ op}$	0...+120	$^\circ\text{C}$
Lagertemperatur storage temperature		t_{stg}	-40...+150	$^\circ\text{C}$

Mechanische Eigenschaften / Mechanical properties

Gehäuse, siehe Anlage case, see appendix			Seite 4	
Si-Element mit Druckkontakt, Lichtzündung Si-pellet with pressure contact, light triggered	Silizium Tablette silicon wafer		55LTN65	
Anpreßkraft clampig force		F	15...24	kN
Gewicht weight		G	typ 650	g
Kriechstrecke creepage distance			25	mm
Feuchtklasse humidity classification	DIN 40040		C	
Schwingfestigkeit vibration resistance	f = 50Hz		50	m/s^2

Mit dieser technischen Information werden Halbleiterbauelemente spezifiziert, jedoch keine Eigenschaften zugesichert. Sie gilt in Verbindung mit den zugehörigen technischen Erläuterungen.
This technical information specifies semiconductor devices but promises no characteristics. It is valid in combination with the belonging technical notes.

Lichtzündbarer Netzthyristor
Light Triggered Phase Control Thyristor

T 553 N 70 TOH

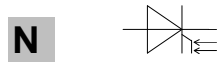

Vorläufige Daten / Provisional Data

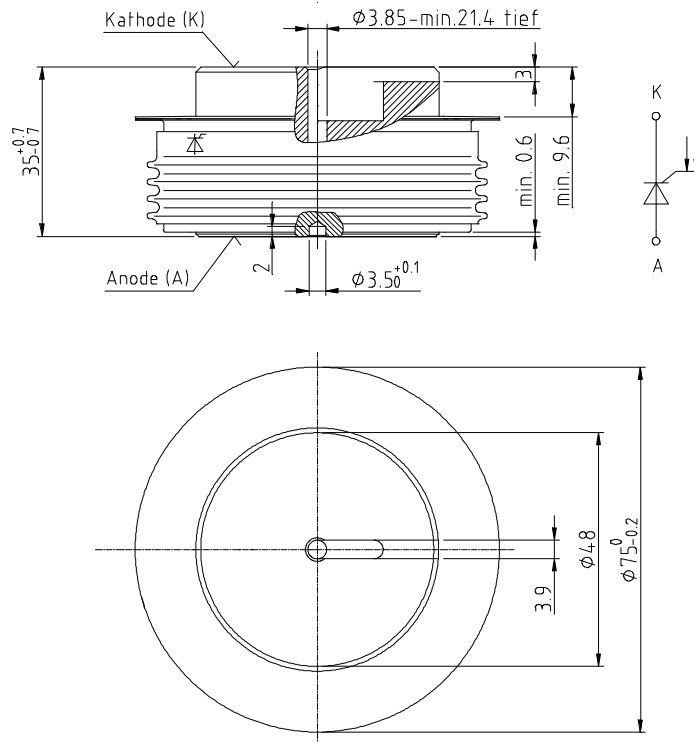

Kriechstrecke:	A,K = 25mm
	A,G = 25mm
	G,K = 1mm

Anpreßkraft 15 kN +60%
Gewicht: ca.550g

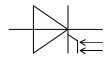

Durchlaßkennlinien $i_T = f(v_T)$
Limiting and typical on-state characteristic

$t_{vj} = 120^\circ\text{C}$

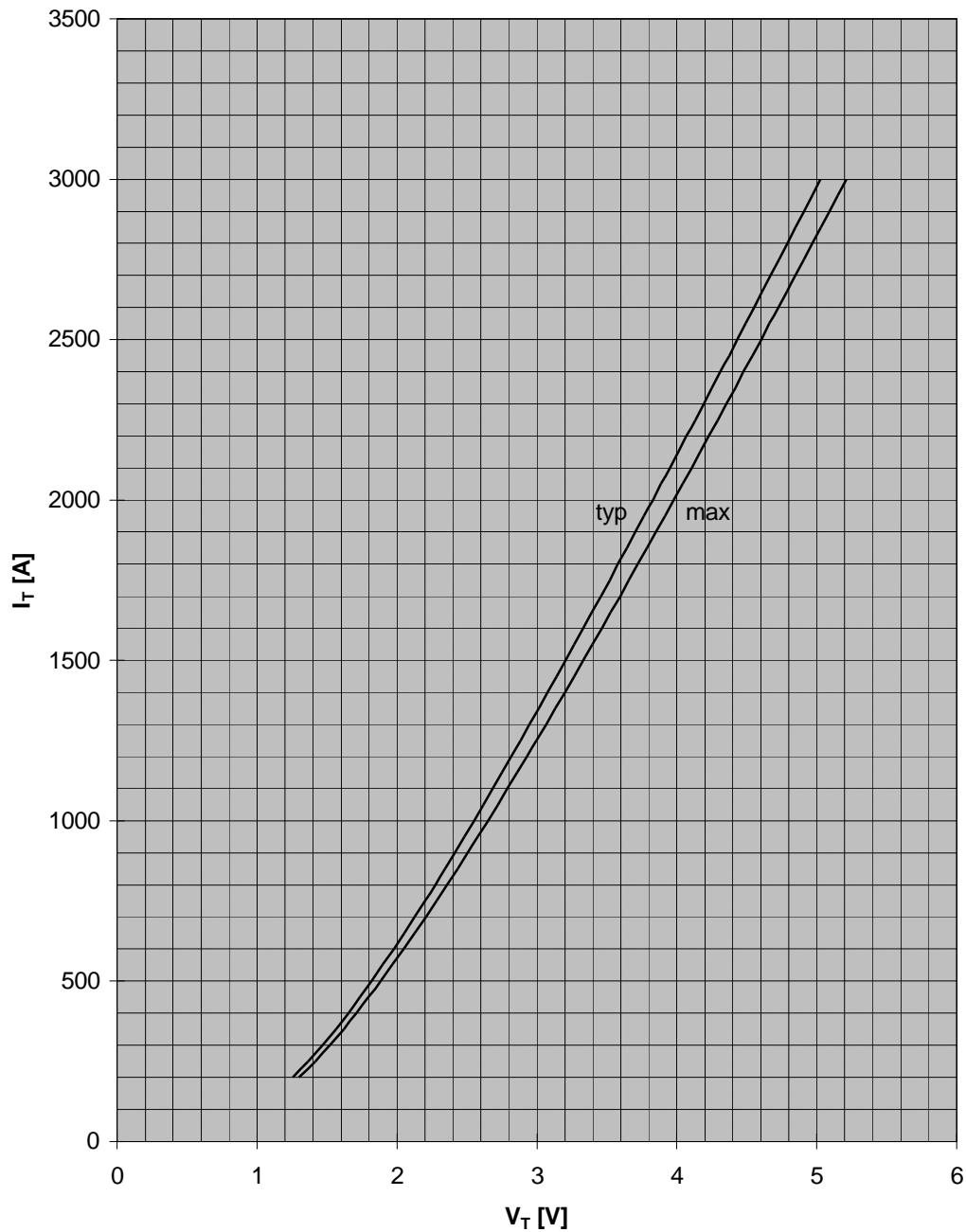

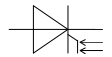

Transienter innerer Wärmewiderstand
Transient thermal impedance $Z_{(th) JC} = f(t)$

	doppelseitige Kühlung		anodenseitige Kühlung		kathodenseitige Kühlung	
	r [K/W]	[s]	r [K/W]	[s]	r [K/W]	[s]
1	0,01048	0,84	0,01917	3,5	0,0396	5,82
2	0,00243	0,132	0,00232	0,45	0,00106	0,45
3	0,00304	0,062	0,0028	0,154	0,00487	0,126
4	0,00272	0,0134	0,00366	0,061	0,00237	0,037
5	0,00033	0,0019	0,00255	0,01	0,0021	0,009
	0,019	-	0,0305	-	0,05	-

$$Z_{thJC} = \sum_{n=1}^{n_{max}} R_{thn} \cdot (1 - e^{-t/t_n})$$

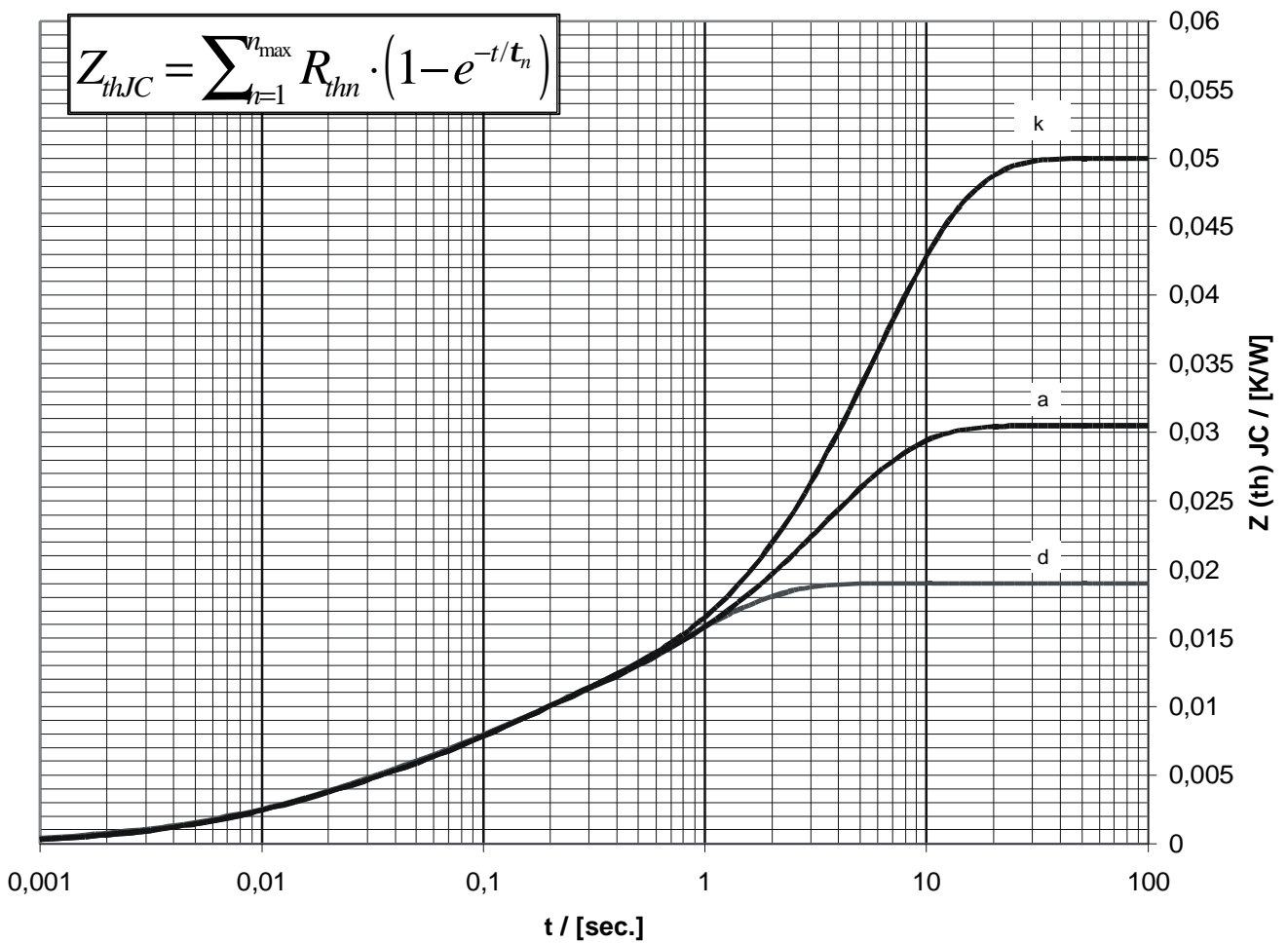

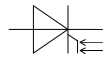

Sperrverzögerungsladung $Q_{rr} = f(-di/dt)$
recovered charge

Nebenbedingungen: $t_{vj} = 120^{\circ}\text{C}$, $I_{TM} = 1000\text{A}$, $v_R = 0,5 \cdot V_{RRM}$, $v_{RM} = 0,8 \cdot V_{RRM}$

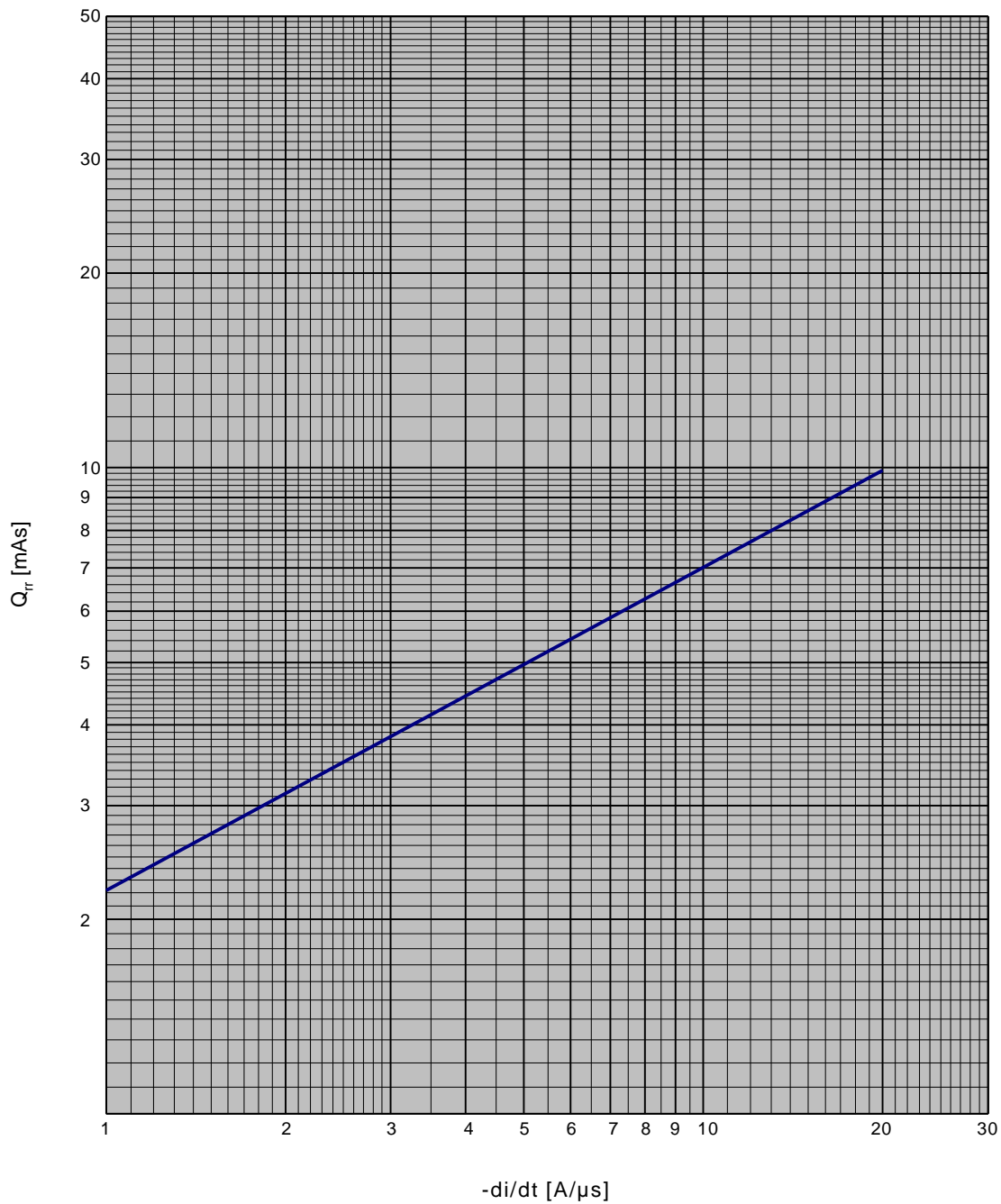

Rückstromspitze / reverse recovery current

$$I_{RM} = f (di/dt)$$

$$t_{vj} = 120^{\circ}C, I_{TM} = 1000A, v_R = 0,5 \cdot V_{RRM}, v_{RM} = 0,8 \cdot V_{RRM}$$

